

Installation manual

WFR 50

©2024

BRUNNER[®]
made in germany.

CONTENTS

1	Basic informations.....	2
2	Appliance description.....	3
3	Delivery contents.....	4
4	Description of parts.....	4
4.1	Overview <small>WFR 50</small>	4
4.2	BG body <small>WFR 50</small>	5
4.3	BG Grate (C015008).....	6
4.4	BG ash pan (C015009).....	7
4.5	BG door (C011007).....	8
4.6	BG ash door (C014004).....	9
4.7	BG air control unit total (C014006).....	10
4.8	BG fireclay (C015005).....	11
4.9	Front variants.....	12
4.10	Support bearing (N002090) (optional).....	12
5	Installation.....	13
5.1	Mounting aid for cast iron dome.....	13
5.2	Set up.....	14
5.3	Air and flue gas connection.....	15
5.4	Fireclay installation <small>WFR 50</small>	19
5.5	Dismantling front (if required).....	23
6	Drawings and technical data.....	24

1 BASIC INFORMATIONS



All instructions delivered with products must be observed. We do not accept any warranty claim or liability for damage resulting from failure to observe these installation instructions!
 Improper installation can cause injury and material damage!

The installation may only be carried out by a registered specialist.

Fireplaces equipped with a water boiler must be pressure-tested after hydraulic connection to the heating system. Masonry work may follow only after this pressure test. Ulrich Brunner GmbH does not cover any costs incurred by necessary dismantling of masonry for rework at water boiler installation or replacement of the boiler.

The floor space of the room must have a suitable structure and sufficient dimensions to ensure proper functioning of the fireplace.

Please note that other installation and assembly instructions are included in other packaging units!

Dimensioning of downstream heat accumulator must be according to valid stove-setting rules.

During installation of the fireplace, all dimensions and minimal clearances of the fireplace casing must be held as specified by the manufacturer.

Fireplaces that meet the requirements of DIN EN 13240 or DIN EN 13229 and that can only be operated as intended with closed combustion chamber door or that have a self-closing firebox door are suitable for multiple occupancy.

All binding national or EU standards and local regulations for the installation of fireplaces must be observed.

All valid stove fitting rules and regulations of local construction law must be observed and followed.

Please follow the relevant regulations of your country.

When these instructions are followed and all works are done properly, this will ensure a safe, energy-saving and environmentally friendly operation of the stove. Pictures shown are not to be considered as complete representations of any kind.

Subject to technical and assortment changes.

Please notify your supplier of any damage which might have occurred during transport.

Please keep these instructions.

Please also take note of the online product documentation provided by:



[General instructions of the Brunner products installation for the stove construction.](#)

(https://www.brunner.de/produktdownloads/kacheloefen-kamine/allgemeine-hinweise-fuer-den-aufbau_de.pdf) laden können.



2 APPLIANCE DESCRIPTION

The heating insert is tested in accordance with EN 13229 and can be installed with either a metal or ceramic post-heating surface. Direct connection of the heating insert to the chimney is not permitted.

The installation of a combustion air duct with outside air supply is possible with this heating insert.

The combustion air is supplied via a connection piece. The combustion air is set by the operator using a combustion air control element.

The appliances are suitable for operation in closed systems (hypocaust). The design of the hypocaust must ensure heat transfer and even heat distribution within the casing so that there is no overheating in the heating chamber at any point. The size of the heat-emitting cladding surfaces must be matched to the heat generator. The required insulation thicknesses specified in the technical data to protect the building surfaces adjacent to the fireplace have been determined for operation with open air grilles in continuous operation (safety test in accordance with EN 13229 - U-value of the test wall 0.7w/m²K) and must be supplemented by suitable measures (e.g. rear ventilation) if necessary.

The appliances in the WF_R series have a grate firing system with which either wood or lignite can be used as fuel. The desired fuel type is set on the appliance using a selector lever that can be reached at any time.

When using wood as fuel, please observe the information on log sizes and storage of firewood!

3 DELIVERY CONTENTS

The delivery consists of different packaging units depending on the configuration of the system.

4 DESCRIPTION OF PARTS

4.1 OVERVIEW WFR 50

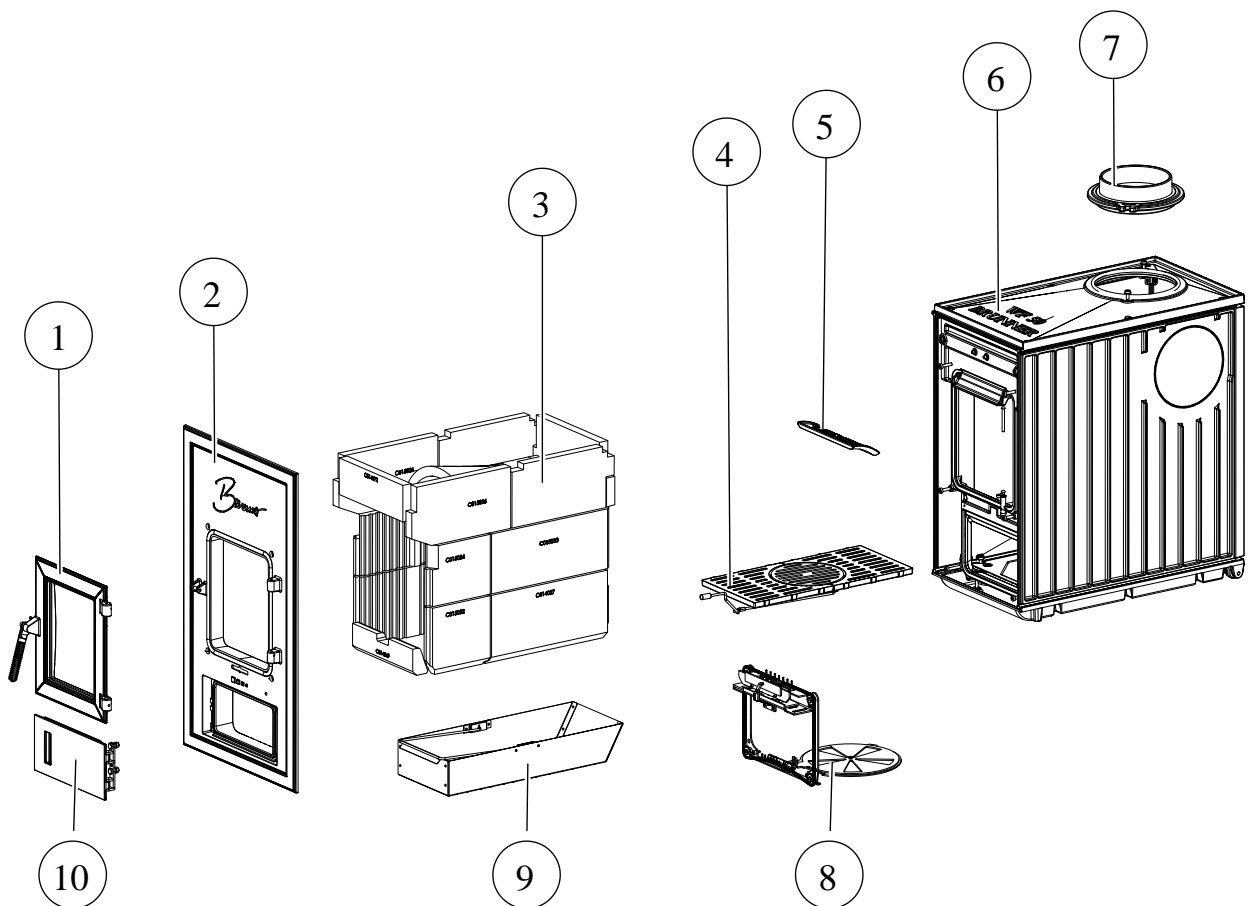

Pos.	Part no.	Designation
1	C011007	BG Door total
2	C014010*	BG front 830x480* (depending on order)
3	C015005	BG Fireclay
4	C015008	BG Grate
5	C014050	Text plate

6	C015007	BG Body
7	C011065	BG Connection piece d=180
8	C014006	BG Air control unit
9	C015009	BG Ash box
10	C014004	BG Ash door

4.2 BG BODY WFR 50

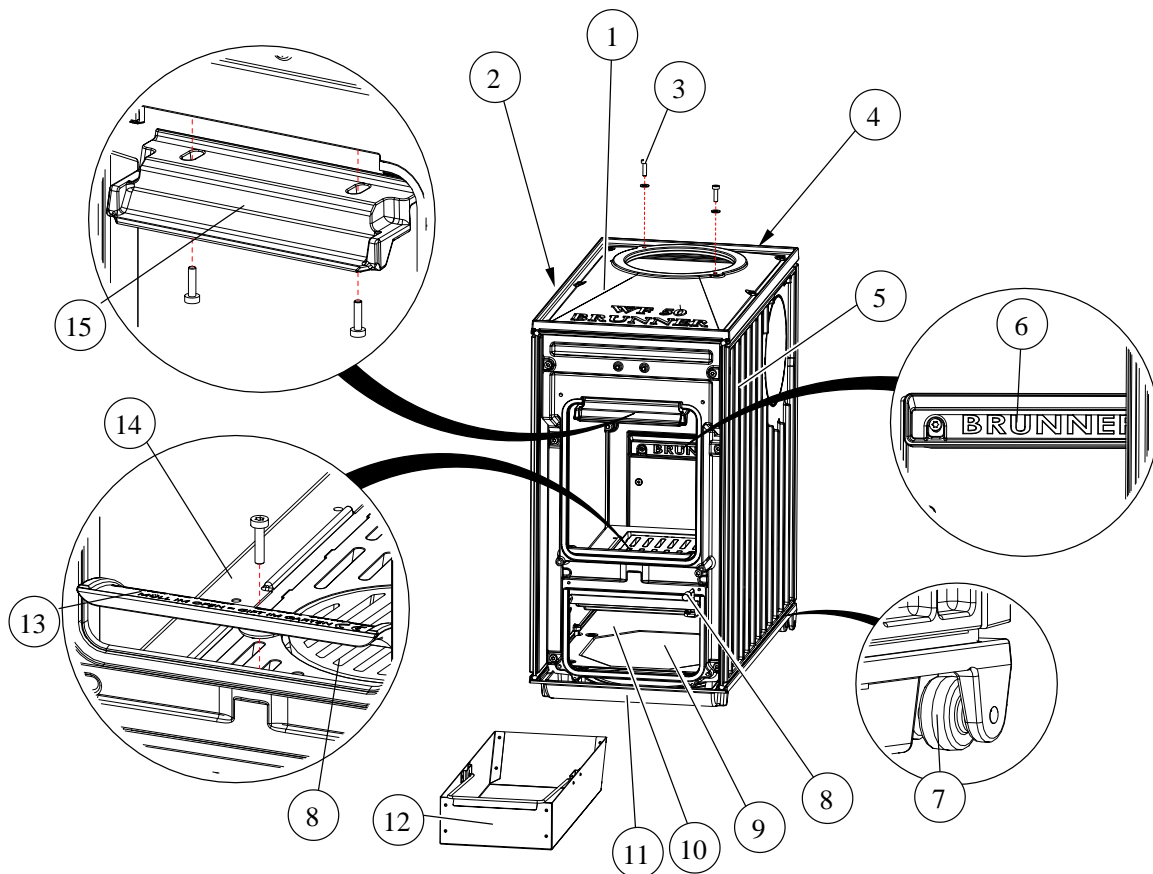

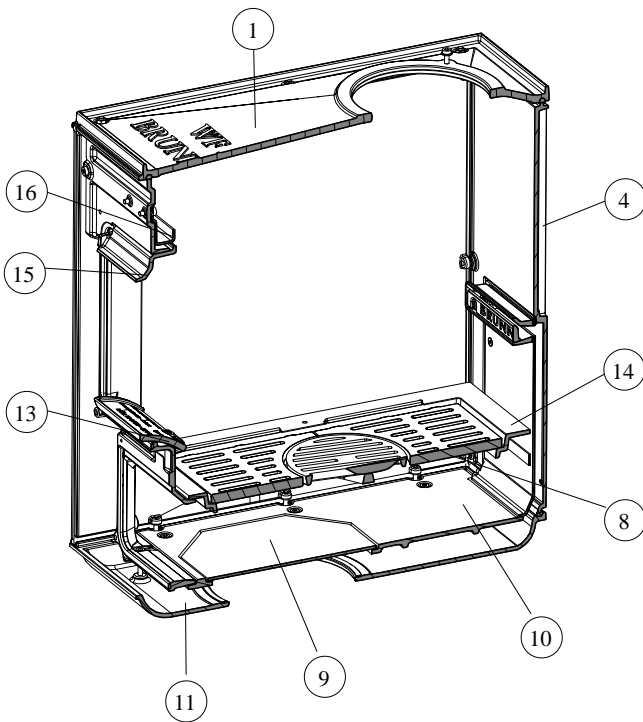

Pos.	Part no.	Designation	pcs.
1	C012015	Hood	1
2	C015018-01	Side panel right	1
3	02523	Cheese head screw M8x25	2
4	C014042-01	Rear panel	1
5	C015018-01	Side panel right	1
6	C011090-02	BG Air inlet	1
7	D003246	Transport roller	2
8	C015008	BG Grate	1
9	C011075	Inspection plate tray	1
10	C012012	Intermediate floor	1
11	C012011	Bottom tray	1
12	C015009	BG ash pan	1
13	C014050	Text plate	1
14	C015017-01	Grate holder	1
15	C011017	Air adjuster	1
16	C014073	Fireclay holding plate front	1

4.3 BG GRATE (C015008)

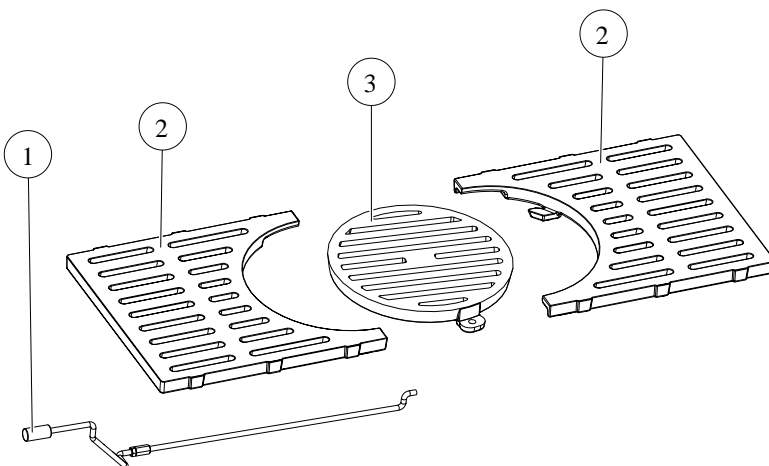

Pos.	Part no.	Designation	pcs.
1	C015015	BG Sliding grate rod	1
2	C015016-00	Grate	2
3	C014022	Rotating grate	1

4.4 BG ASH PAN (C015009)

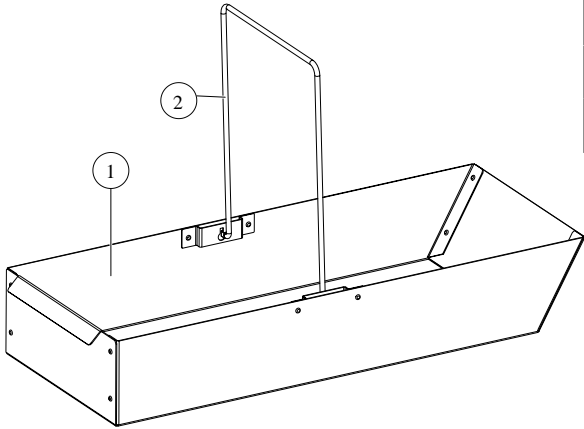
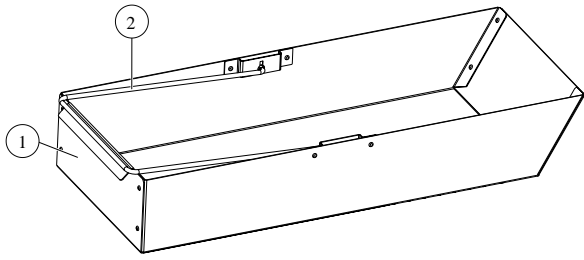

Pos.	Part no.	Designation
1	C015027	Sheet metal box
2	C015028	Ash box Carrying handle

4.5 BG DOOR (C011007)

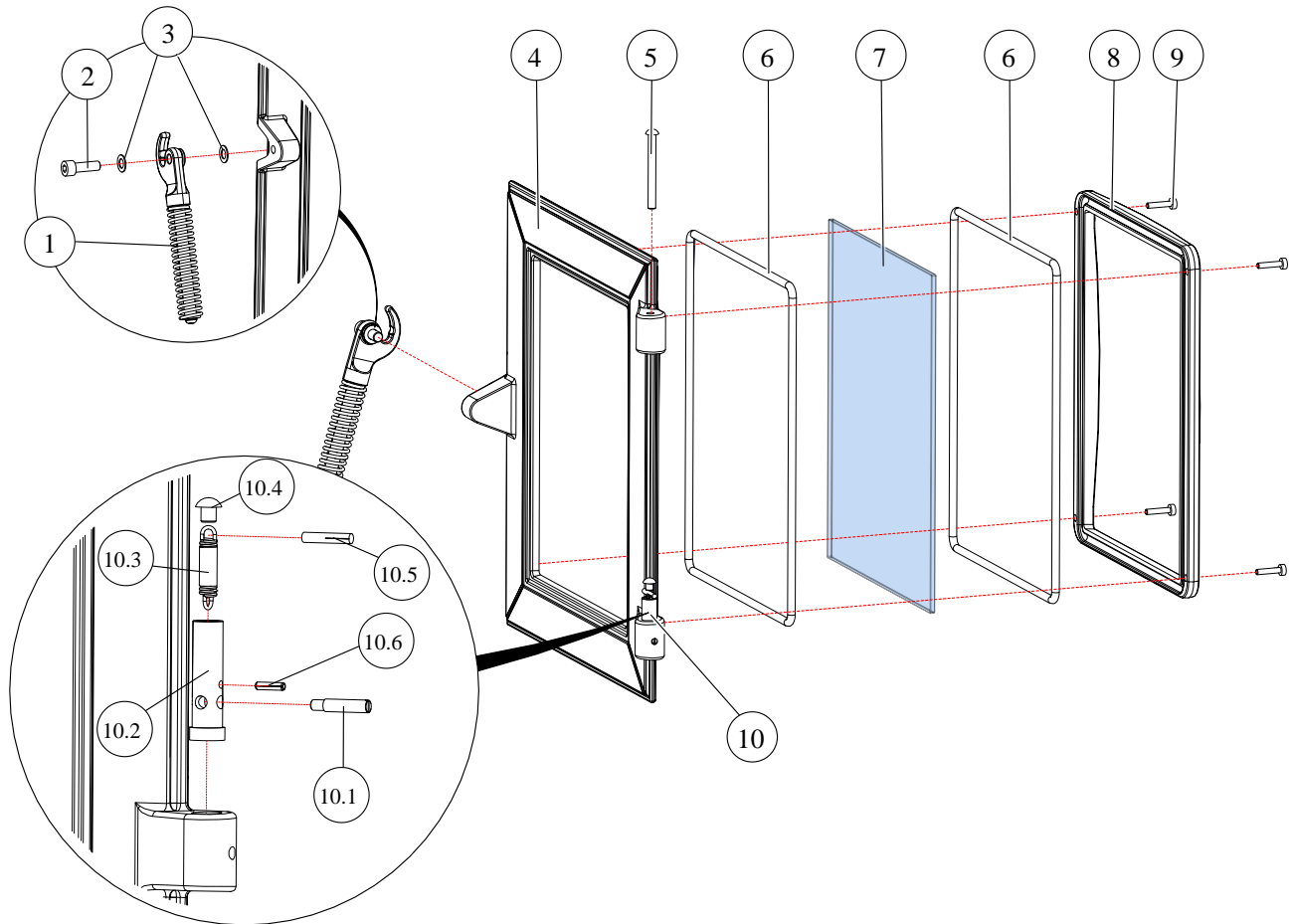

Pos.	Part no.	Designation	Pcs.	Pos.	Part no.	Designation	pcs.
1	C011059	Door handle	1	2	00647	Door bolt screw HF-HBO	1
3	800010	Spring washer B8	2	4	C011018	Door leaf	1
5	00569	Semicircular rivet M6x60	1	6	C011055	Door window seal inside	2
7	C011019	Outer pane	1	8	C011054	Interior door window frame	1
9	02096	Cheese head screw M5x20	4	10	C011024	BG Door closer	1
10.1	800143	Shank screw M5x25	1	10.2	C011033	Hinge pin	1
10.3	C011020	Door pull spring	1	10.4	900360	Semicircular rivet 6x6	1
10.5	900350	Dowel pin D4x22	1	10.6	800431	Clamping sleeve D3x12	1

4.6 BG ASH DOOR (C014004)

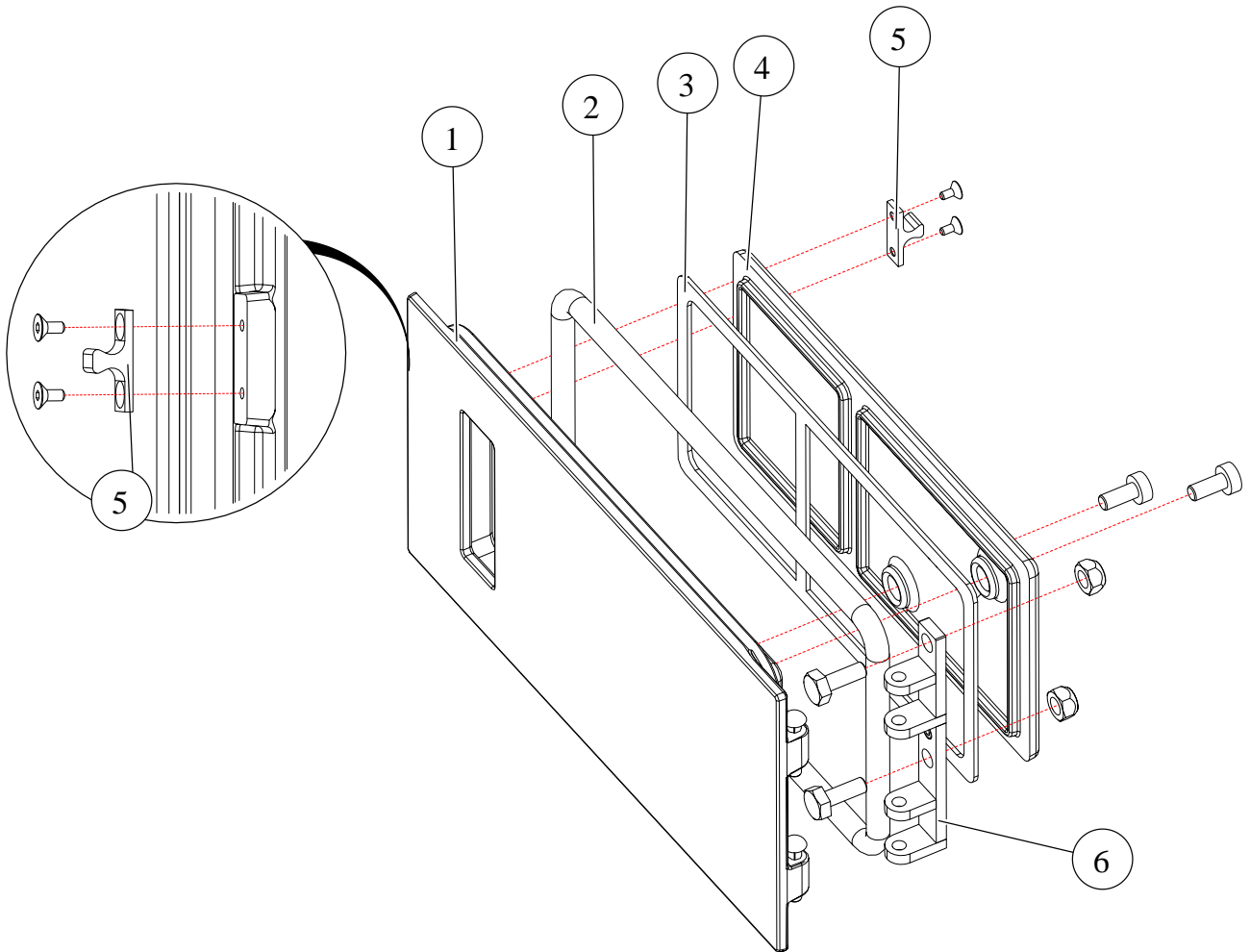

Pos.	Part no.	Designation	Pcs.	Pos.	Part no.	Designation	pcs.
1	C014024-01	Front ash door	1	2	C014071	Ash door sealing cord	1
3	C014063	Rear ash door seal	1	4	C014060	Rear ash door	1
5	C014066	Latch ash door	1	6	800063	Countersunk screw M4x8	2
7	02522	Cheese head screw TORX M8x16	2	8	800157	Hexagon nut with clamping part M8	2
9	C014062	BG Hinge ash door	1	10	00634	Hexagon head screw M8x20	2
11	800450	Half-round grooved nail 6x30	2				

4.7 BG AIR CONTROL UNIT TOTAL (C014006)

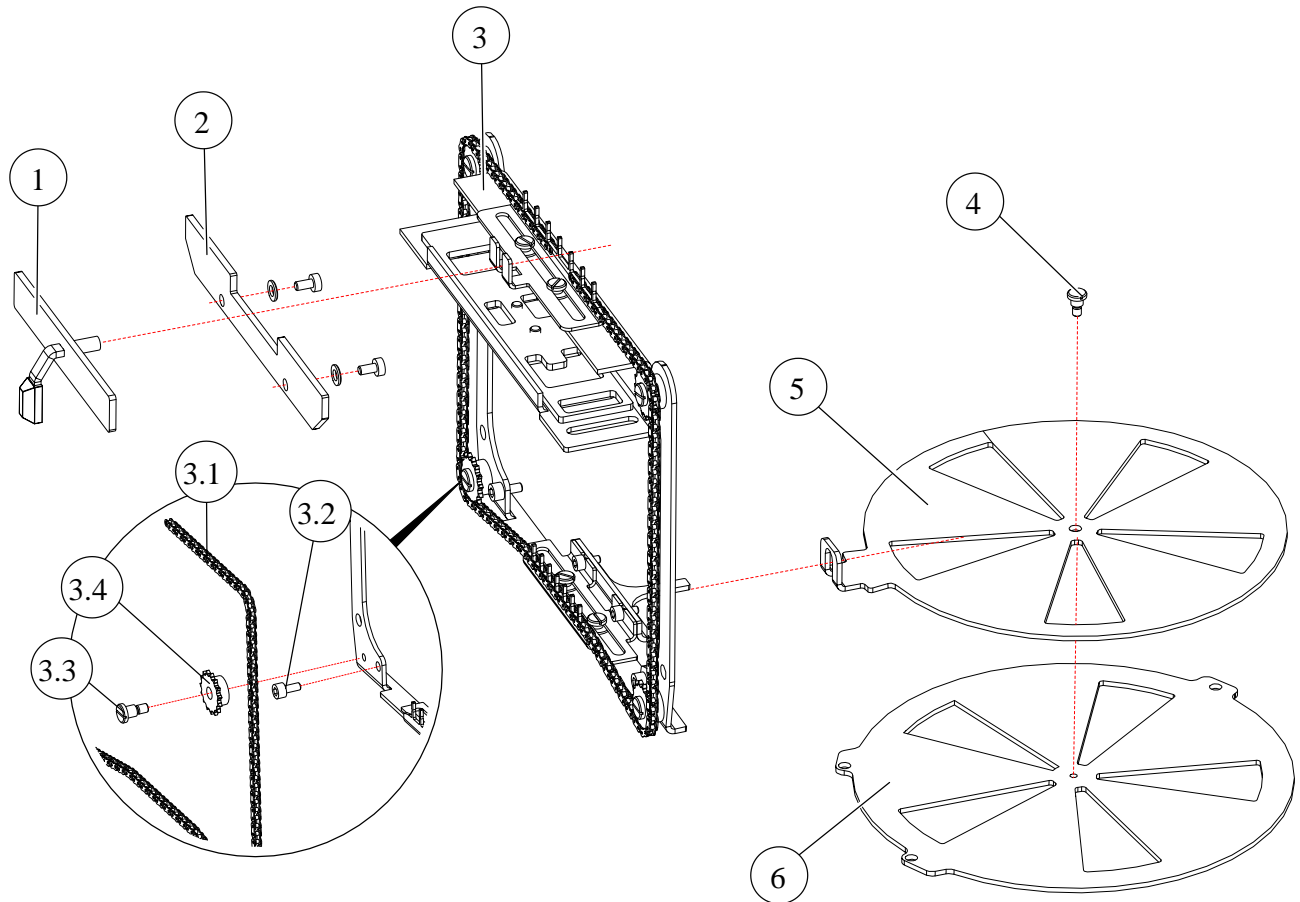

Pos.	Part no.	Designation	Pcs.	Pos.	Part no.	Designation	pcs.
1	C011084	BG Operating unit	1	2	C011083	Air actuator retaining plate	1
3	C014048	BG Air actuator unit	1	3.1	C014046	Chain	1
3.2	800037	Cheese head screw M6x12	4	3.3	800423	Flat head screw M6x8	4
3.4	C014039	Sprocket disk	4	4	800016	Flat head screw M5x5	1
5	C014045	Air sliding plate	1	6	C011056	Air inlet plate D250	1

4.8 BG FIRECLAY (C015005)

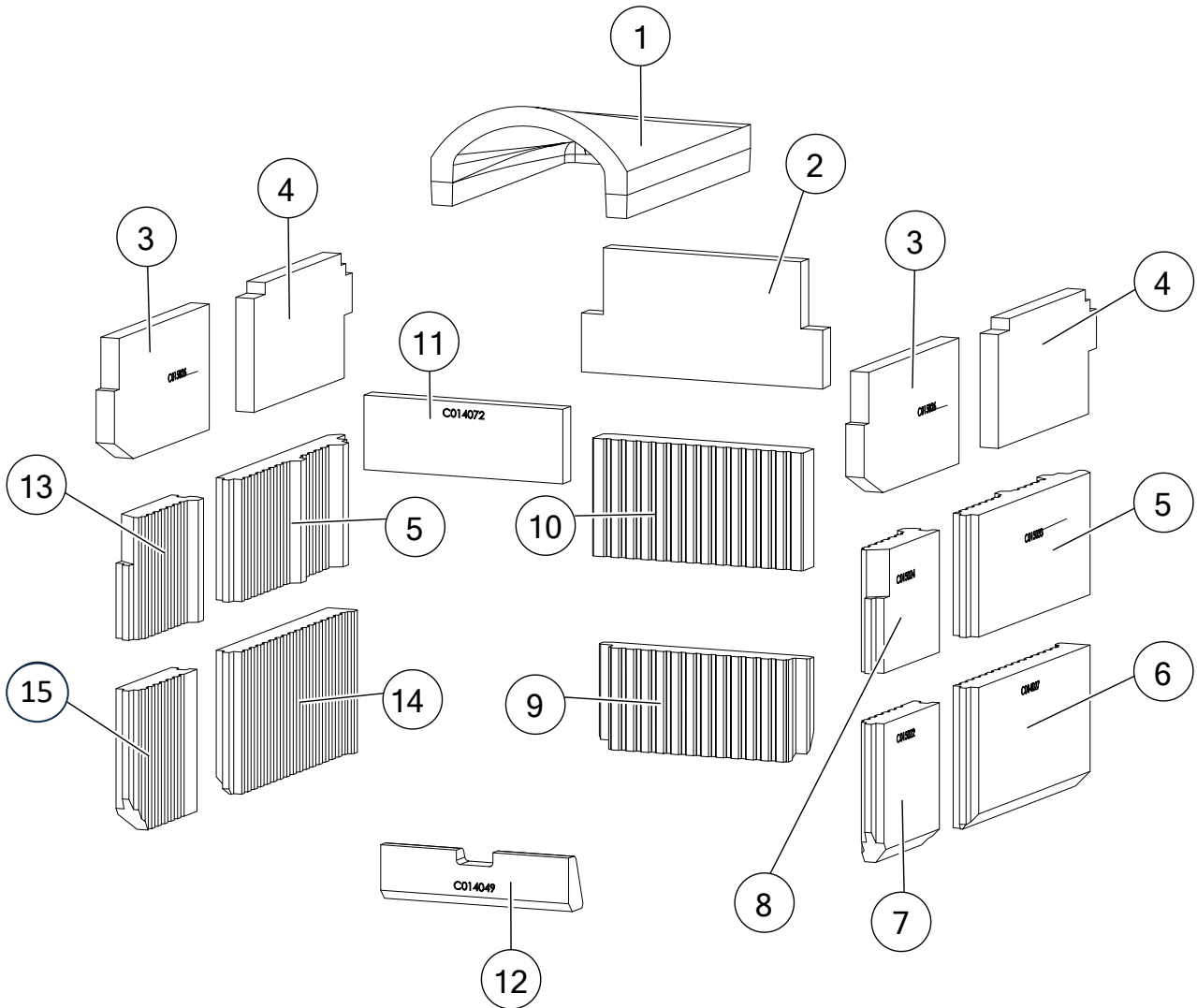

Pos.	Part no.	Designation	pcs.	Pos.	Part no.	Designation	pcs.
1	C012023	Deflection block bent	1	2	C015034	Top back stone	1
3	C015026	Side wall block top front	2	4	C015025	Side wall block top rear	2
5	C015033	Side wall block top right	2	6	C014027	Side wall brick bottom right	1
7	C015022	Side wall brick bottom front right	1	8	C015024	Side wall block top front	1
9	C014026	Rear wall block bottom	1	10	C014030	Top back brick	1
11	C014072	Fireclay front top	1	12	C014049	Wedge brick	1
13	C015031	Side wall stone top front	1	14	C014028	Side wall block bottom left	1
15	C015023	Side wall brick bottom front left	1				

4.9 FRONT VARIANTS

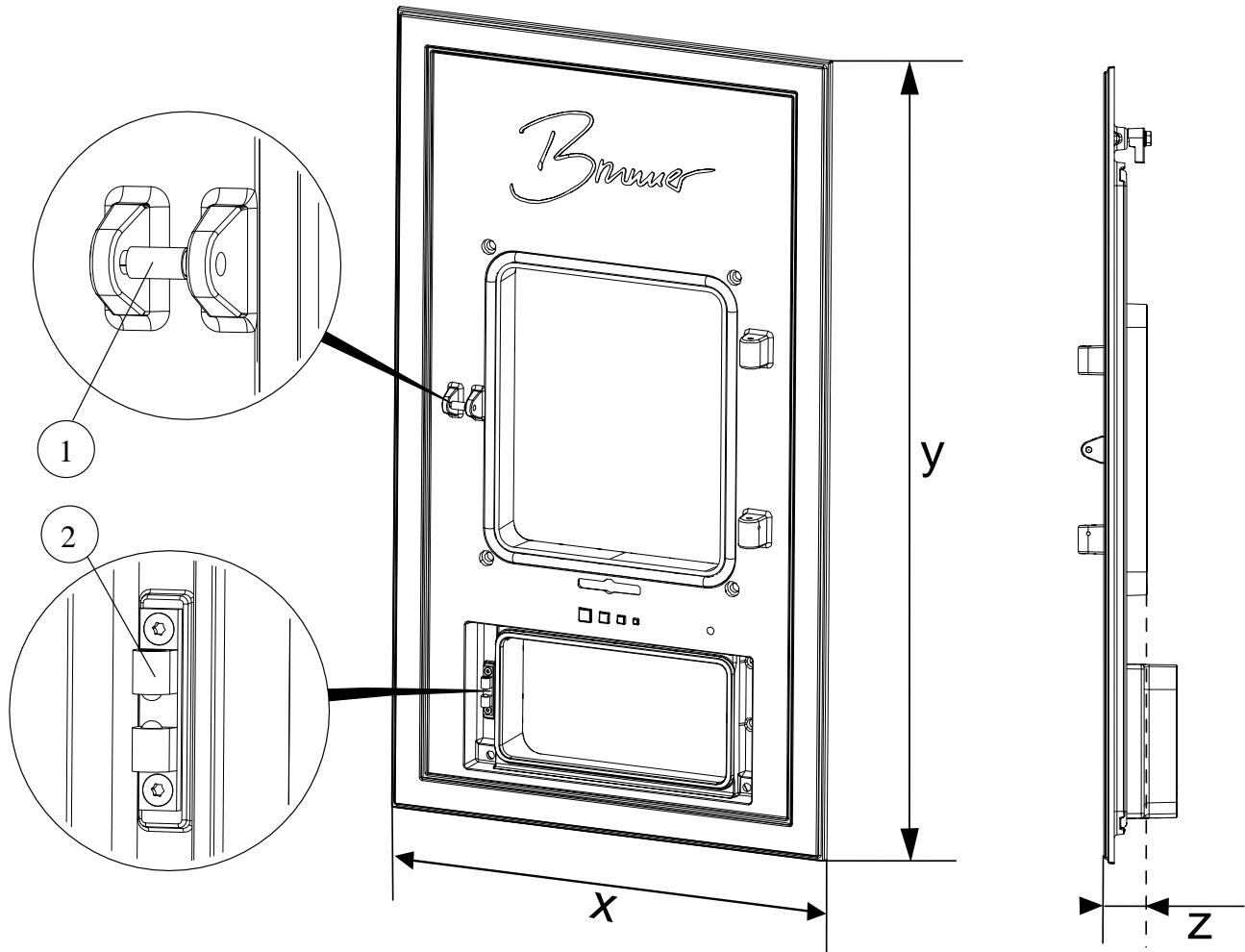

Front variants	x	y	z
Front 830x480	480	830	44
Front 790x420	420	790	44
Front 895x480	480	895	44
Front with air grille	480	1060	44

Pos.	Part no.	Designation
1	C011070	Handle roller
2	C014067	Ash door snap lock

4.10 SUPPORT BEARING (N002090) (OPTIONAL)

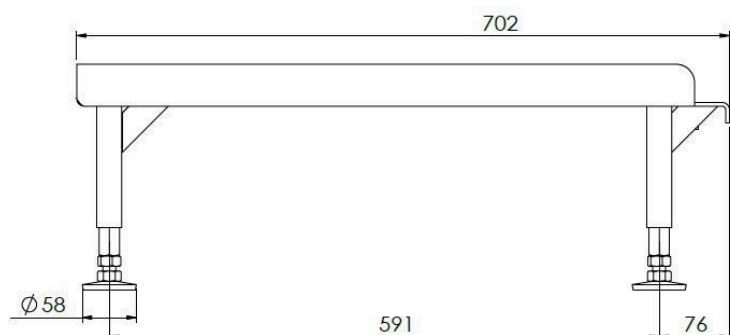
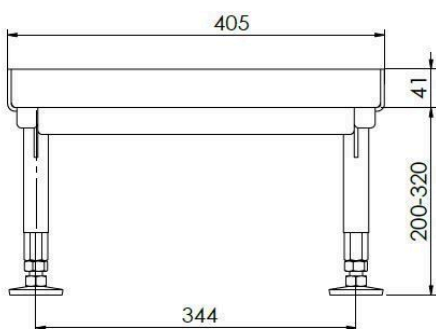

5 INSTALLATION

The WF 50 / WFR 50 can be installed with different reheating surfaces. The options range from prefabricated metallic or ceramic post-heating surfaces to a structure with individually created ceramic strips.

The technical regulations must be observed in all cases!

Ensure that the individual elements are permanently and firmly connected!

Adequate cleaning facilities must be provided!

Combustion air setting

The combustion air is set at the factory. However, if a new setting is necessary, please observe the adjacent information. The air gap is adjusted using the screws marked X.

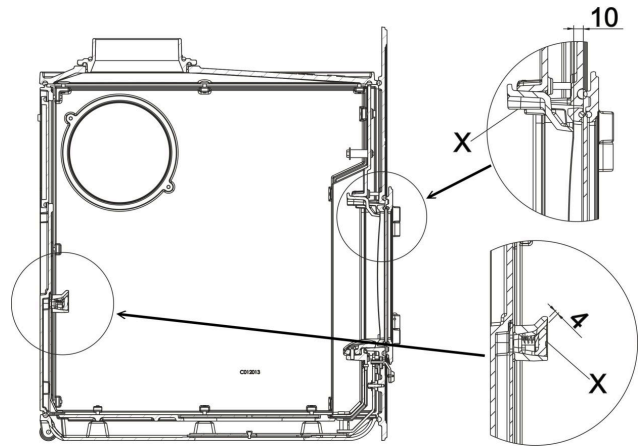

Im. 1: Combustion air setting

5.1 MOUNTING AID FOR CAST IRON DOME

The clamping bracket (X) is used to pull the cast cover forwards into the seal at the front plate during installation.

The clamping bracket can be removed once the cast iron dome has been fitted.

We recommend removing the clamping bracket, as the front plate cannot be removed from the front for servicing when the clamping bracket is fitted!

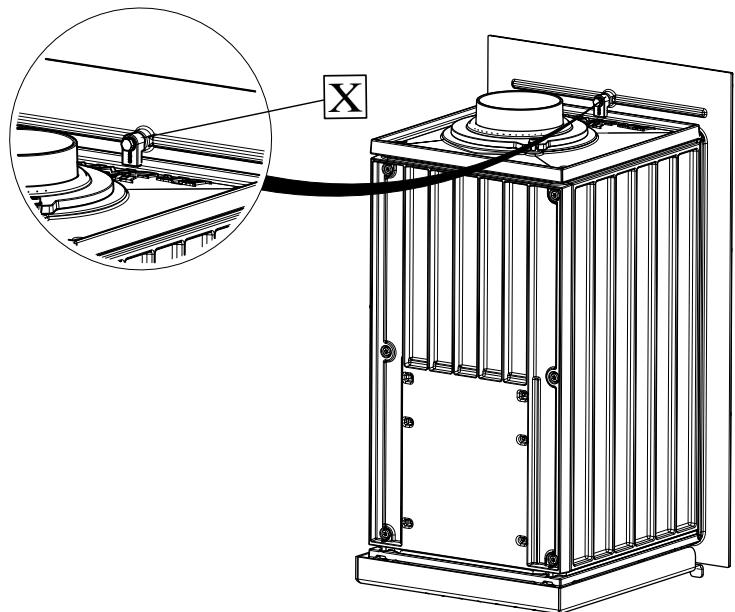

5.2 SET UP

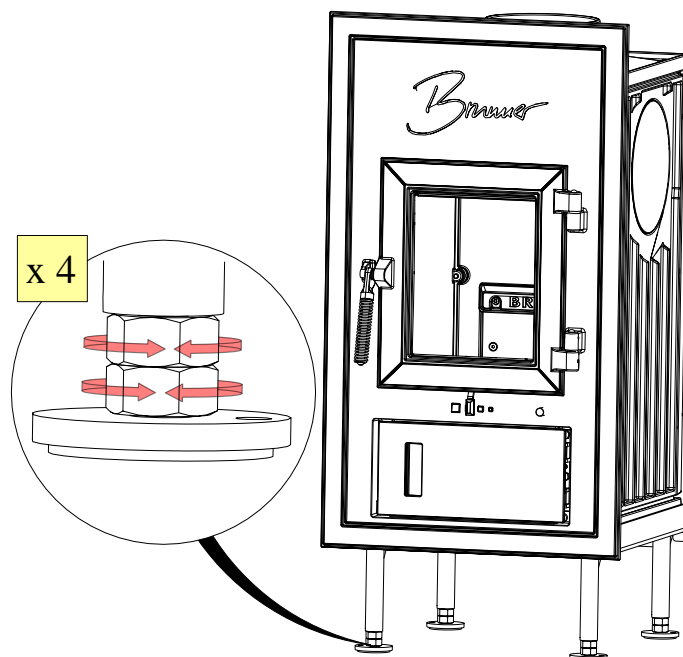
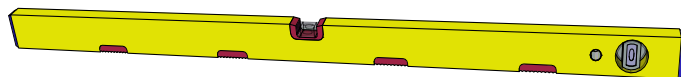
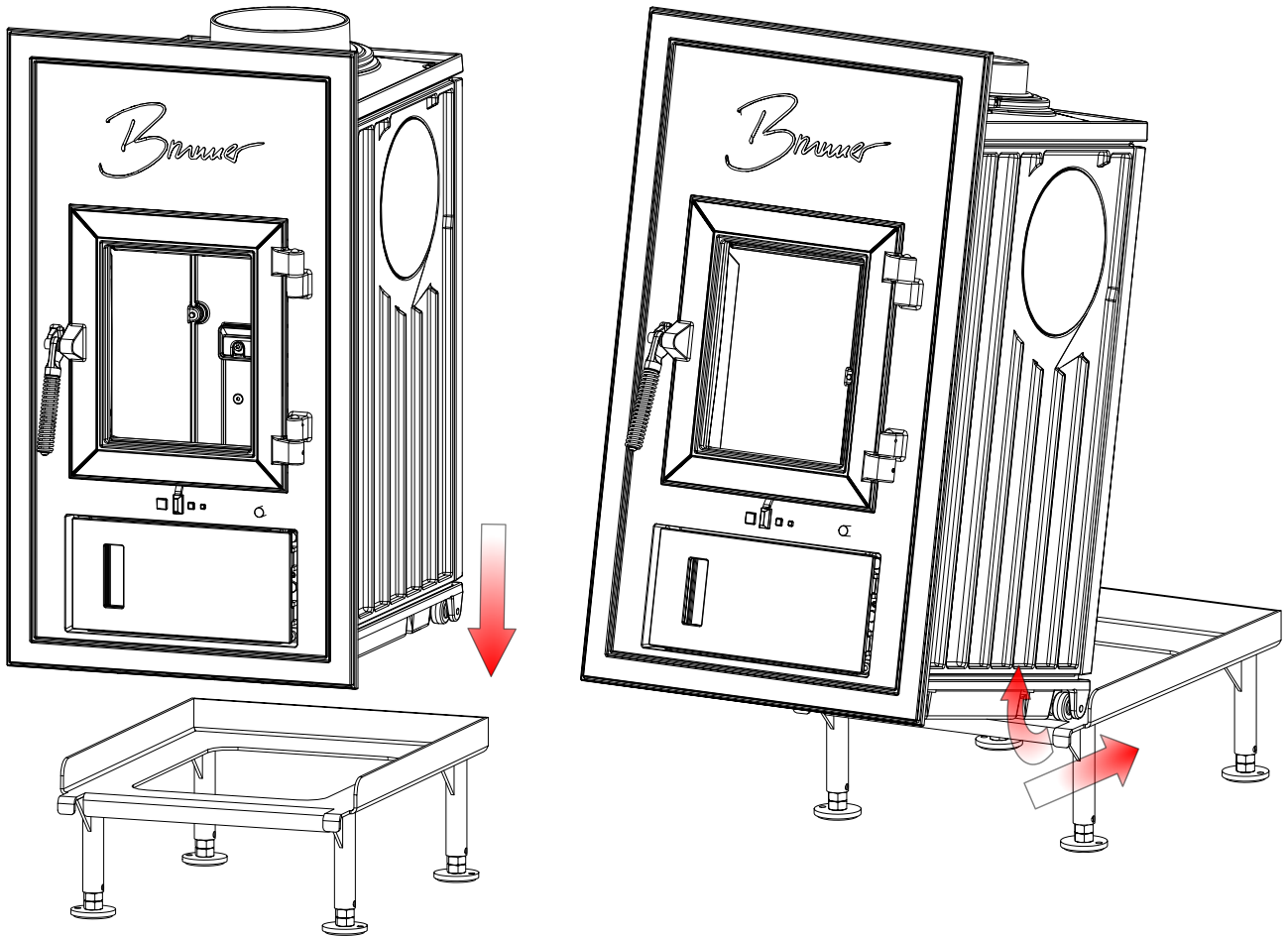

5.3 AIR AND FLUE GAS CONNECTION

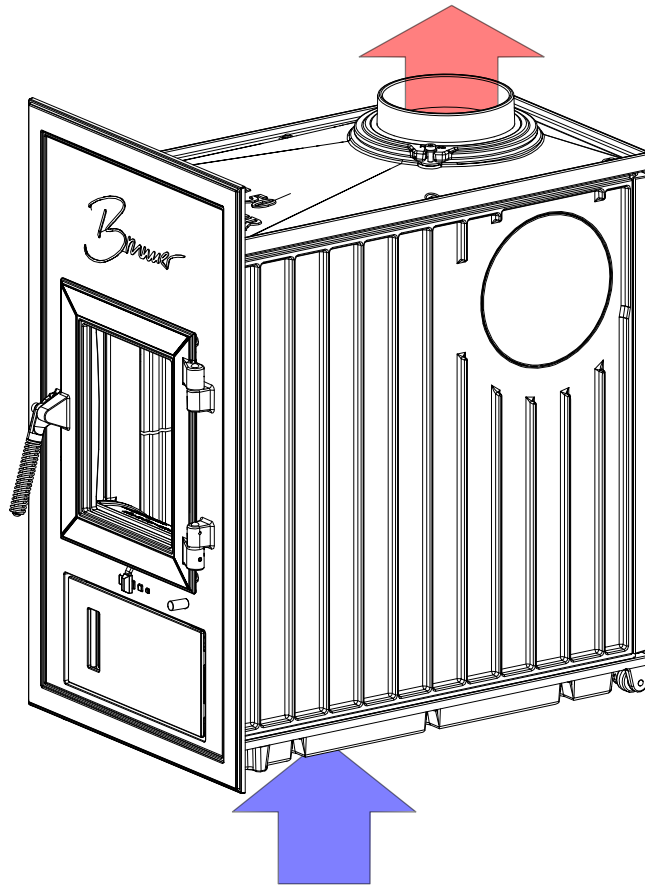

FITTING THE COMBUSTION AIR CONNECTION (OPTIONAL)

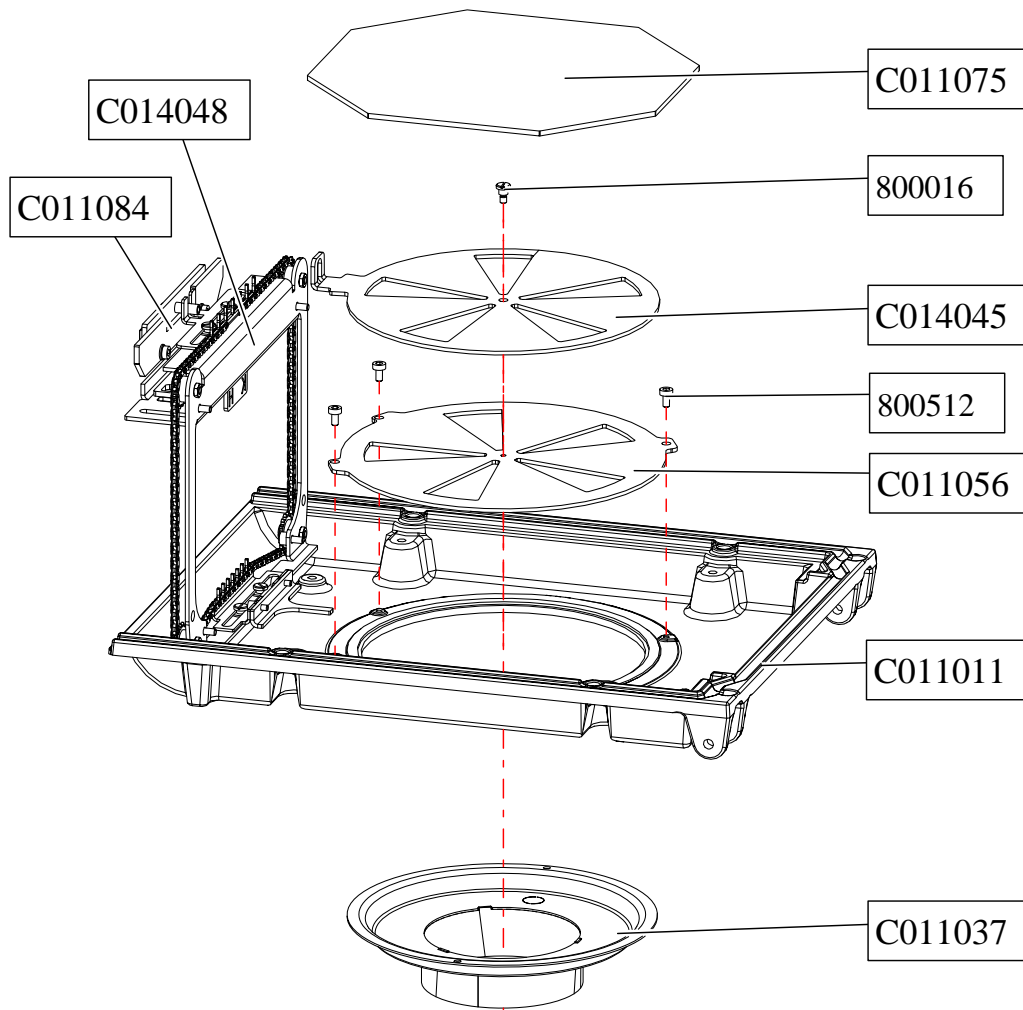

Part no.	Designation	Part no.	Designation
C014048	Air control unit	C011075	Inspection plate for tray
C011084	Control unit	800016	Flat head screw M5x5
C014045	Air sliding plate	800512	Cheese head screw M6x10
C011056	Air inlet plate D250	C011011	Machined floor pan
C011037	Combustion air connection		

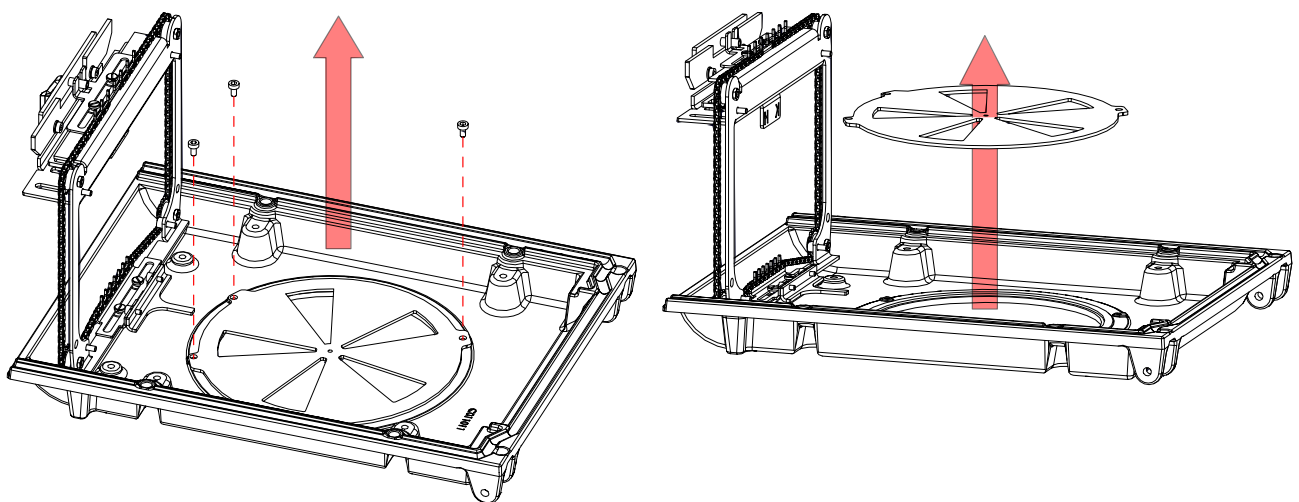
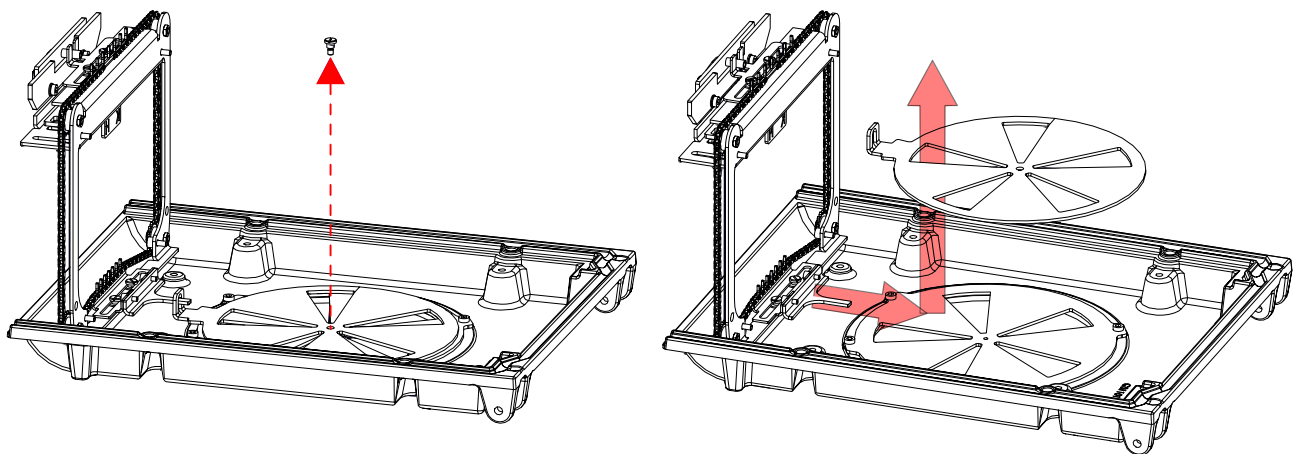
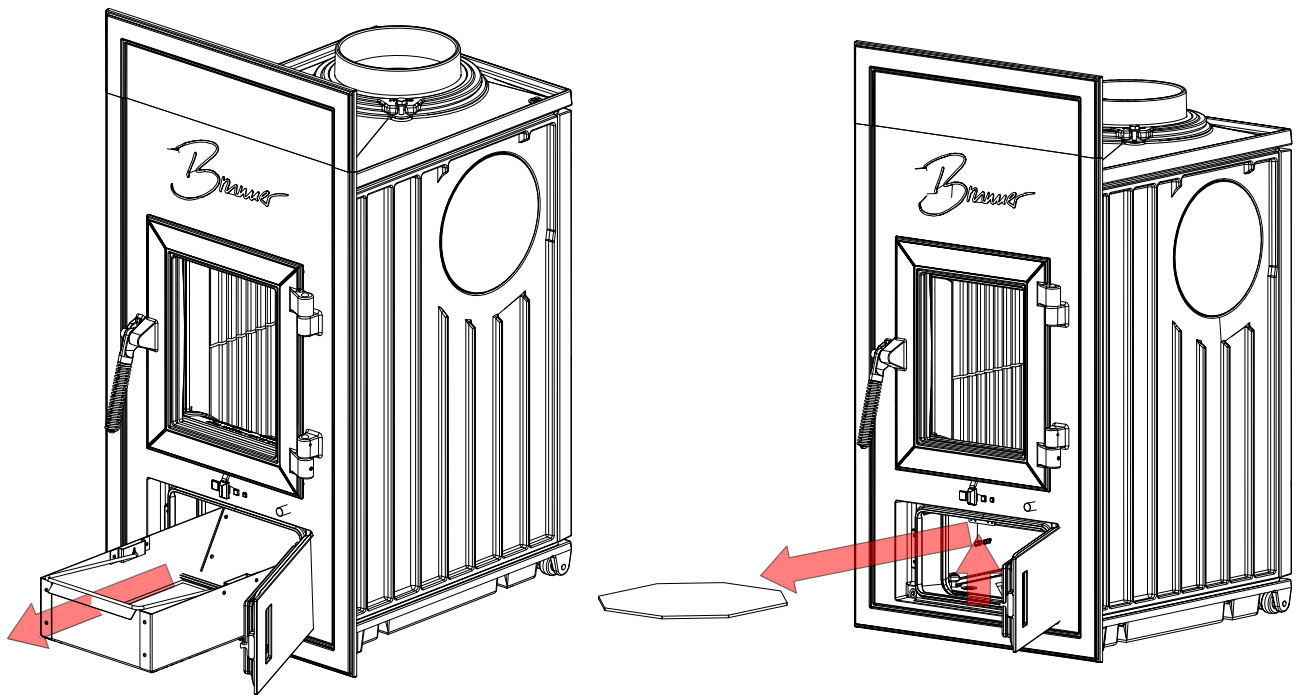

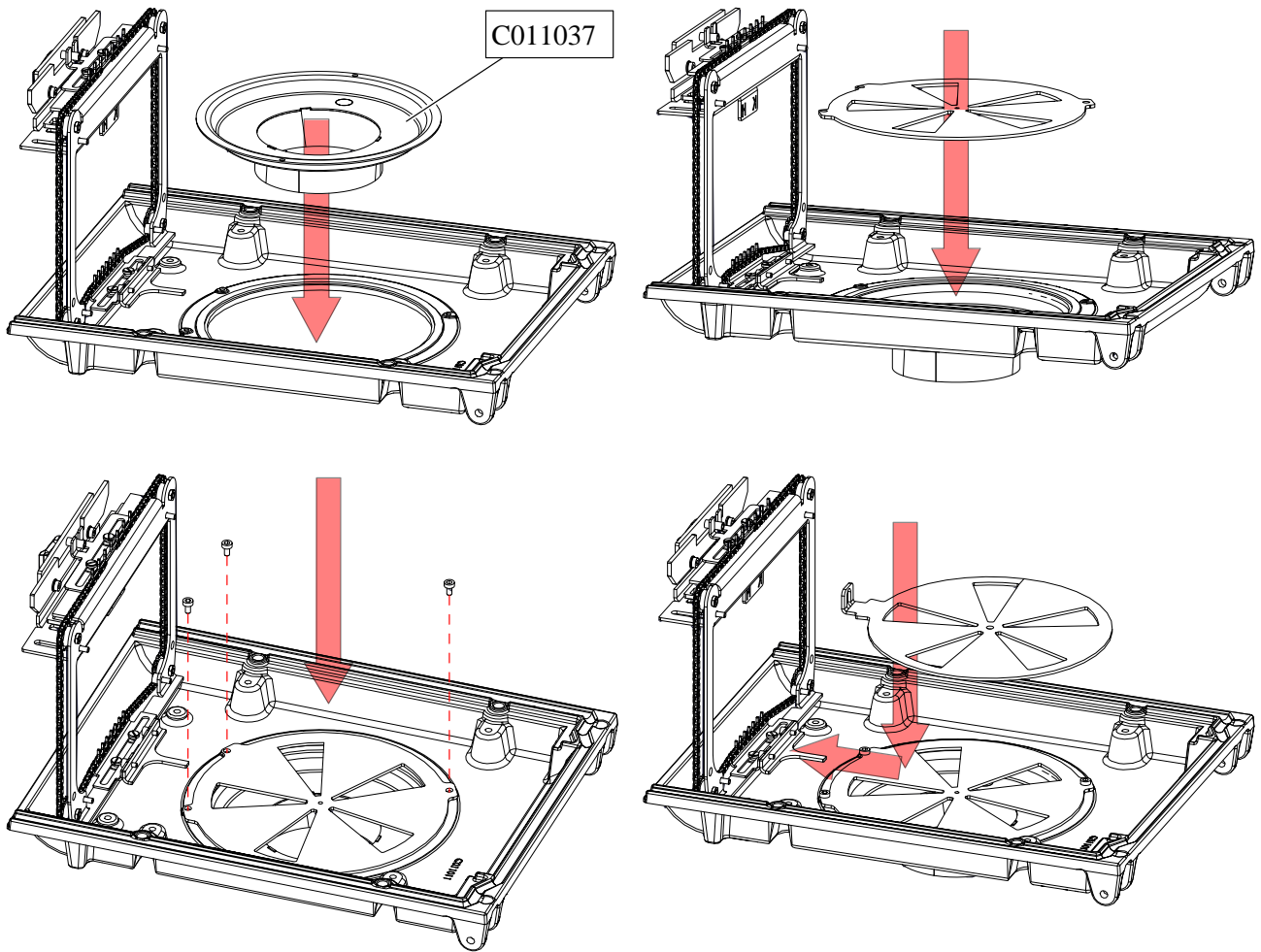

Title Title

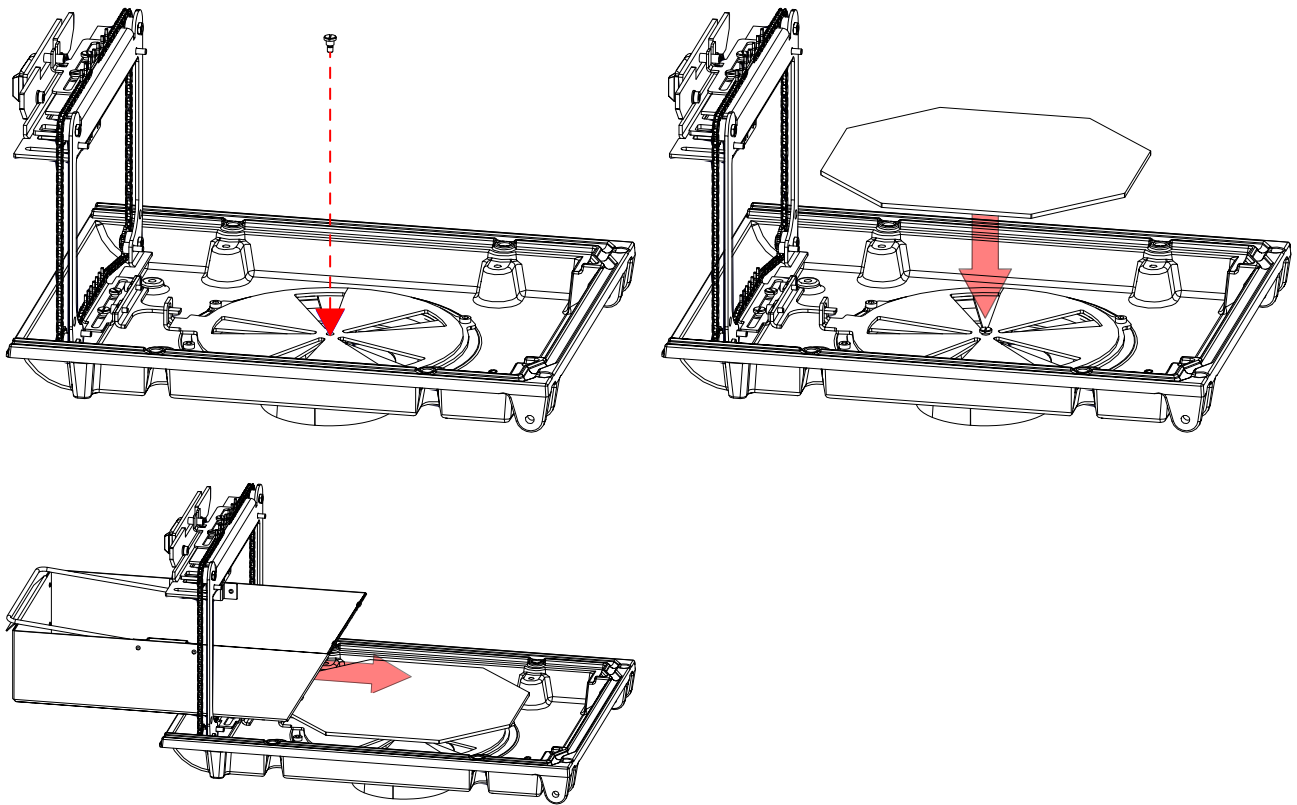

5.4 FIRECLAY INSTALLATION WF_R 50

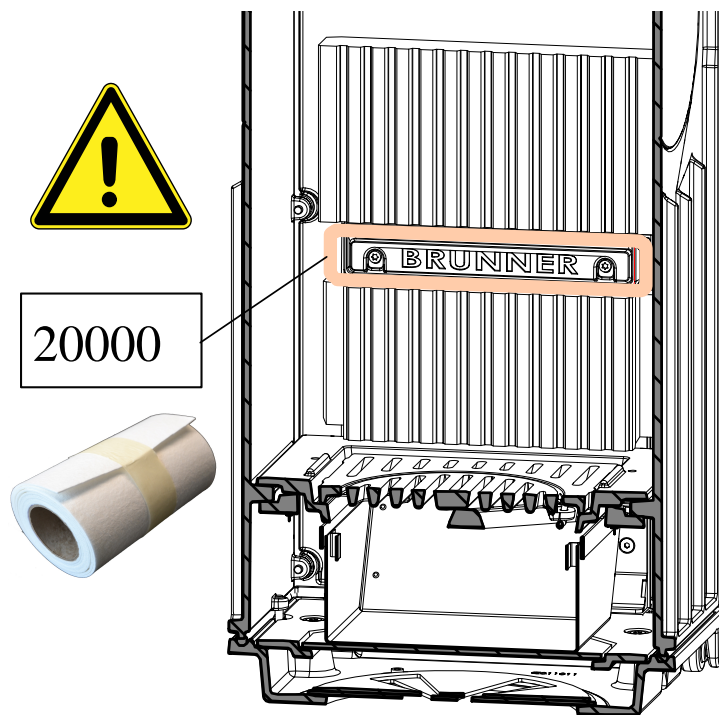



C014030

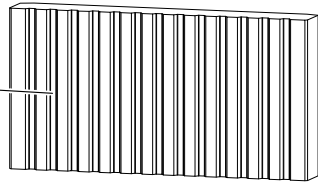

C014026

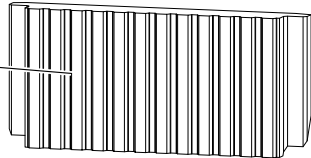

C014027



C014027



C015022



C015022

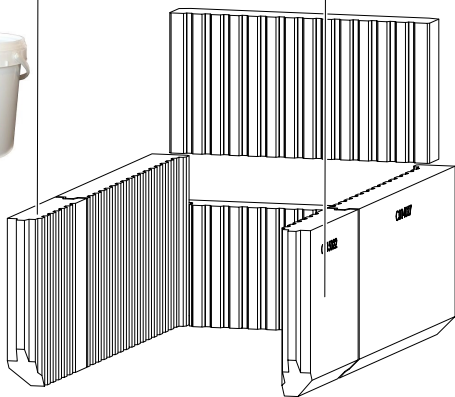

C015033



C015033

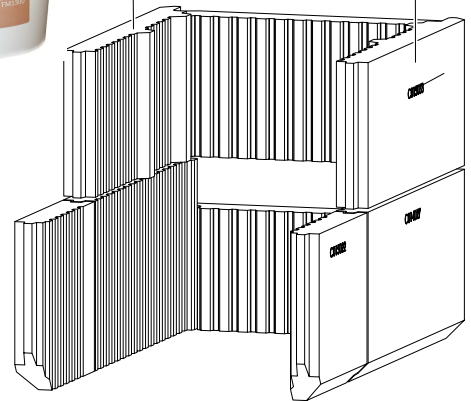

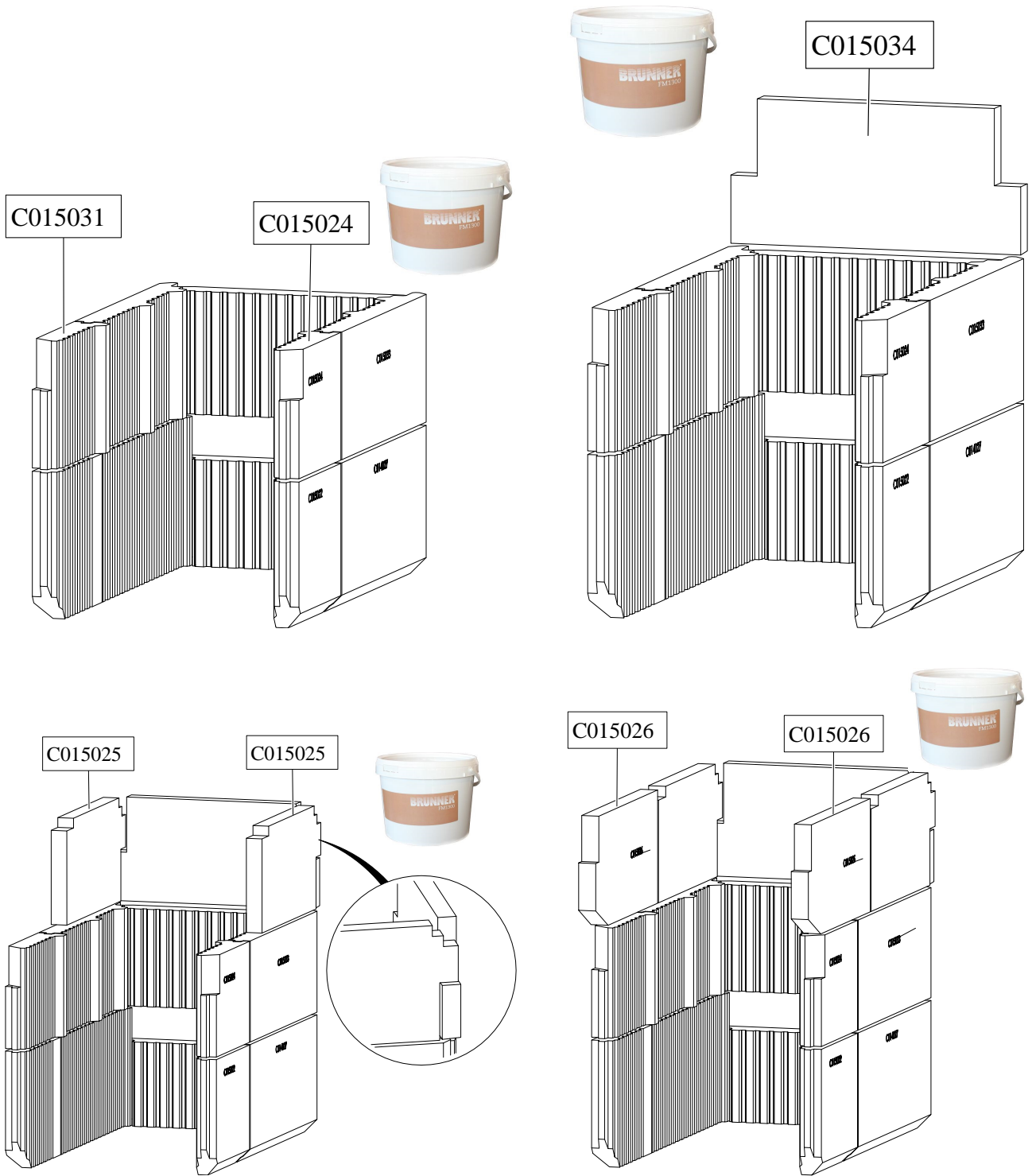

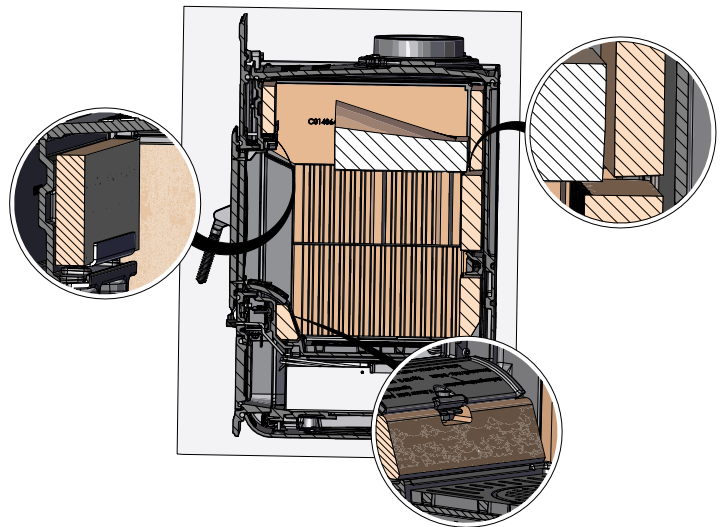
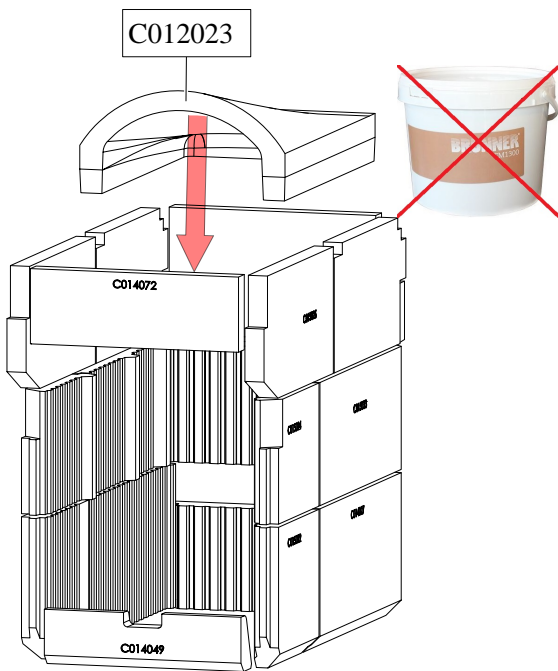
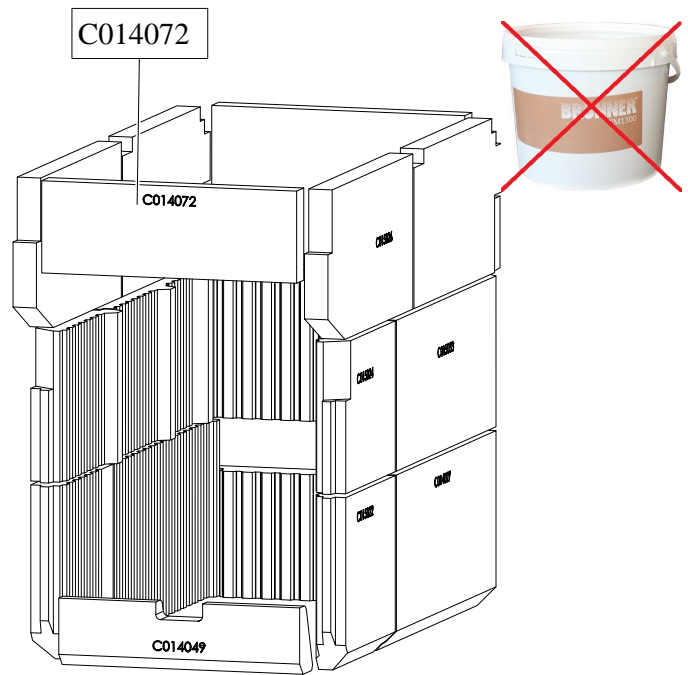
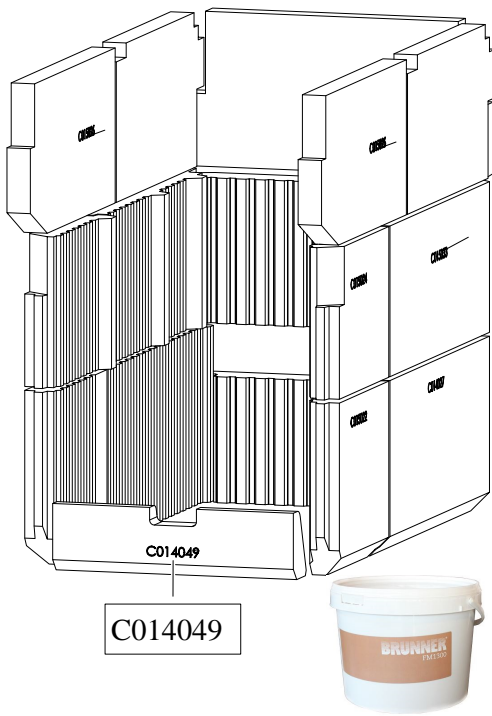

5.5 DISMANTLING FRONT (IF REQUIRED)

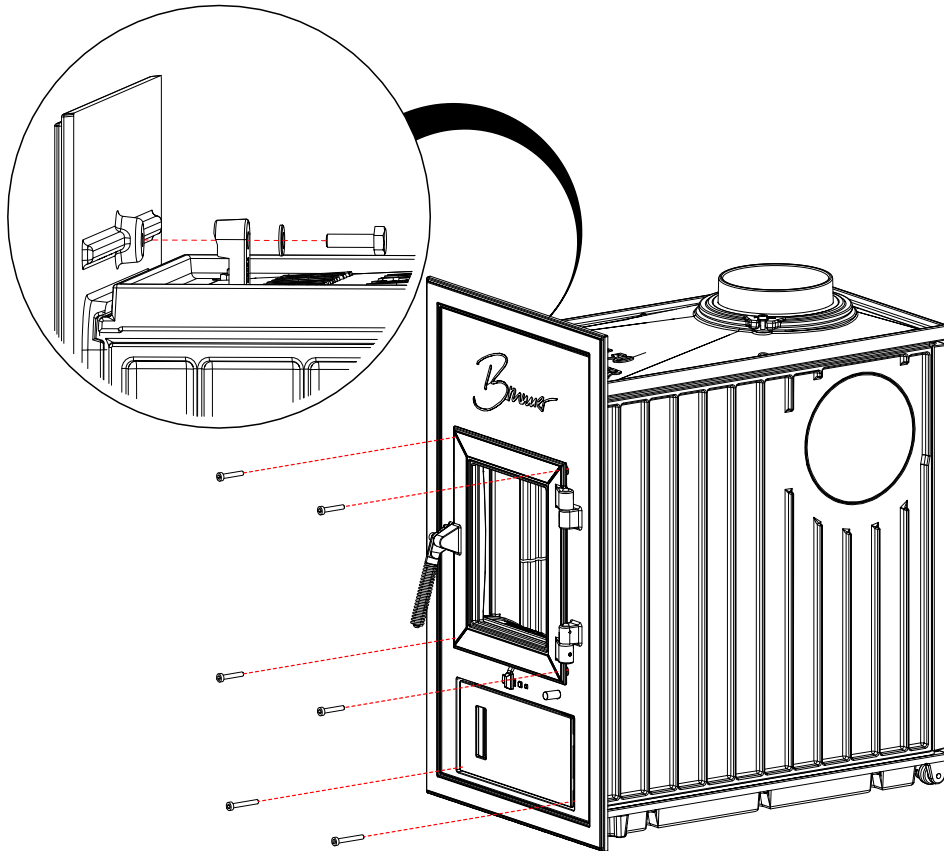

Dimension sheets - WF_R 50

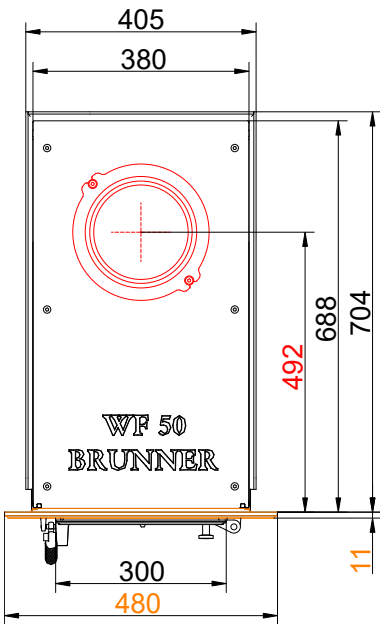
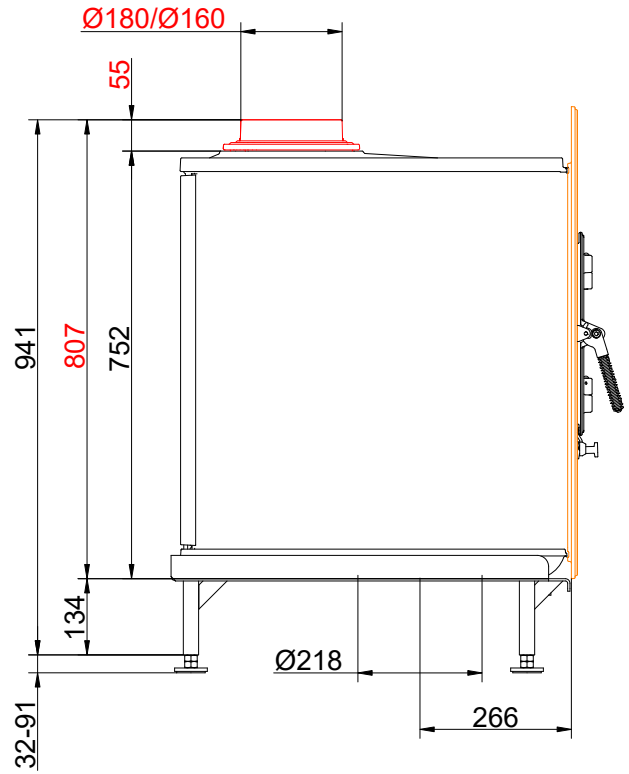
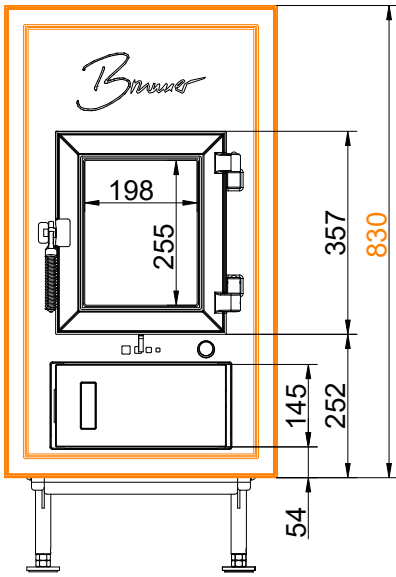

... cast iron front plate 830 X 480

Dimension sheets - WF_R 50

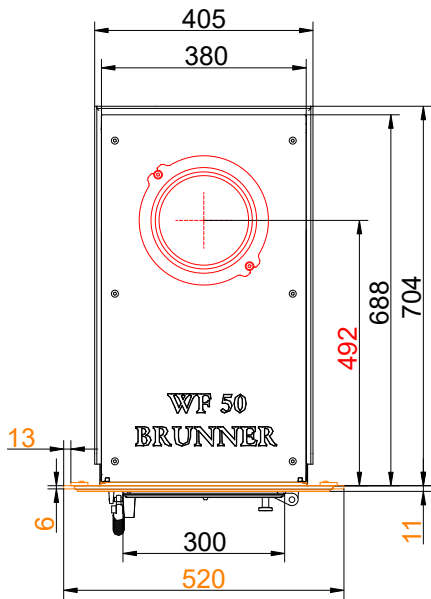
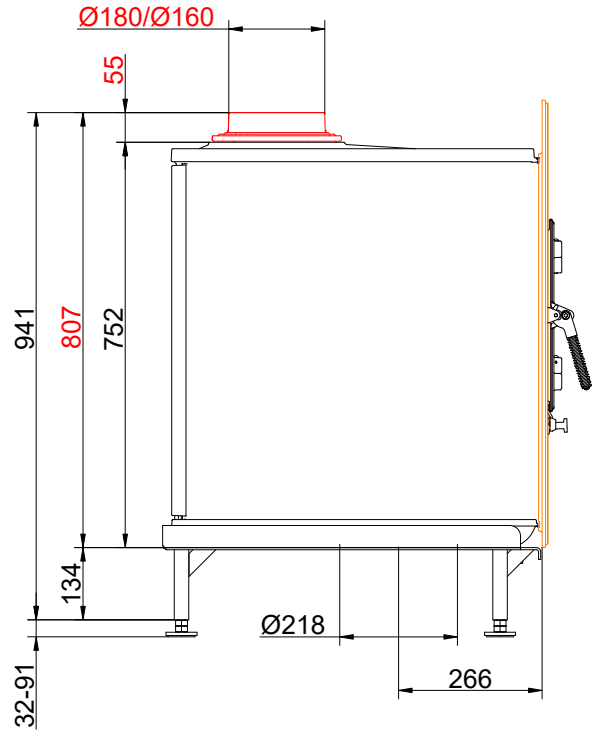
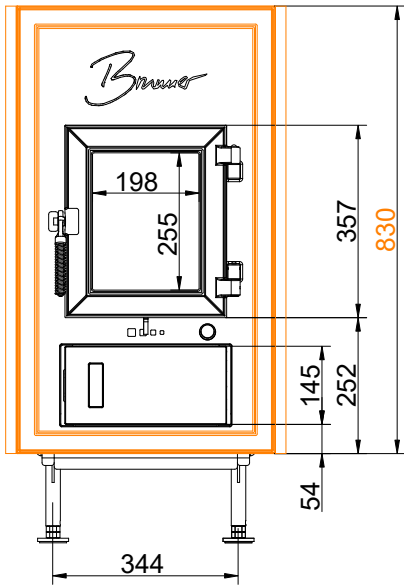

... cast iron front plate 830 X 520

Dimension sheets - WF_R 50

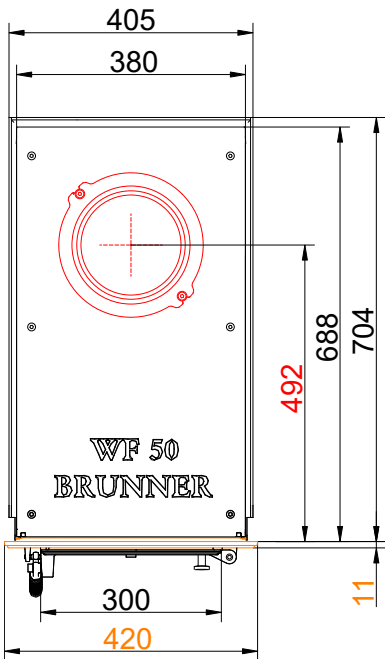
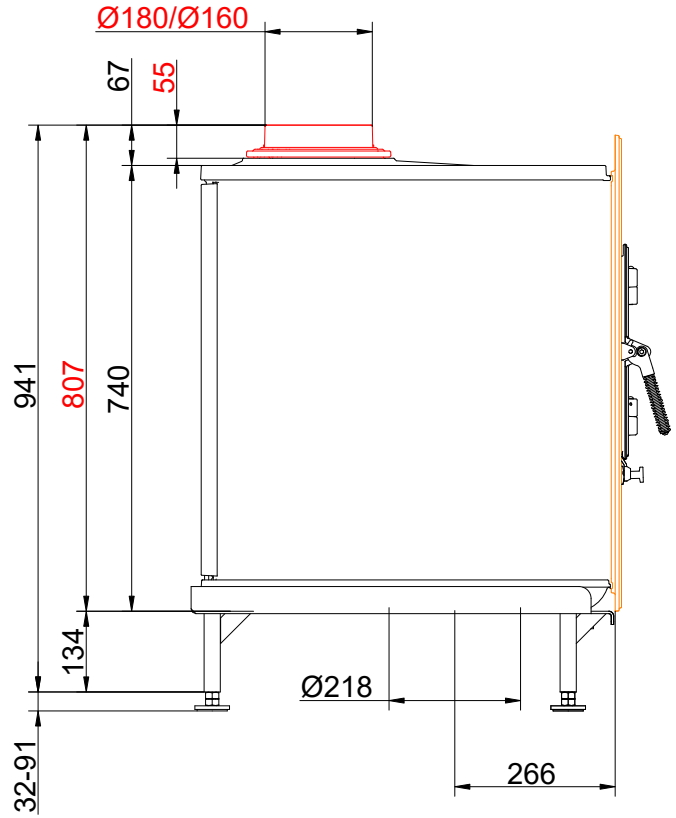
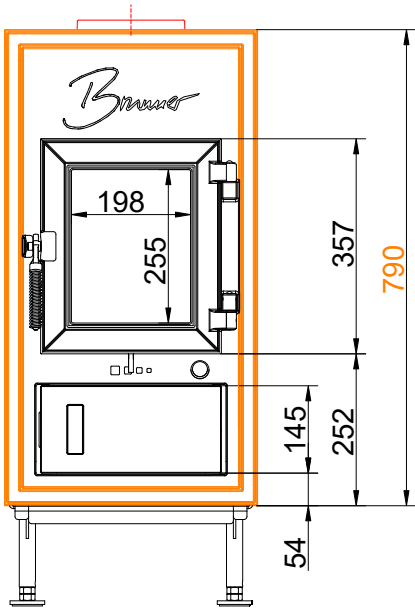

... cast iron front plate 790 x 420

Dimension sheets - WF_R 50

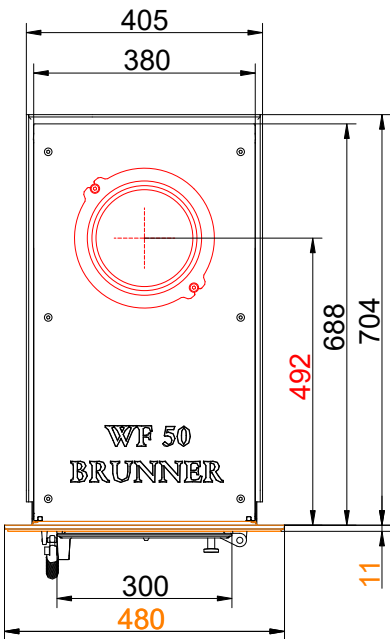
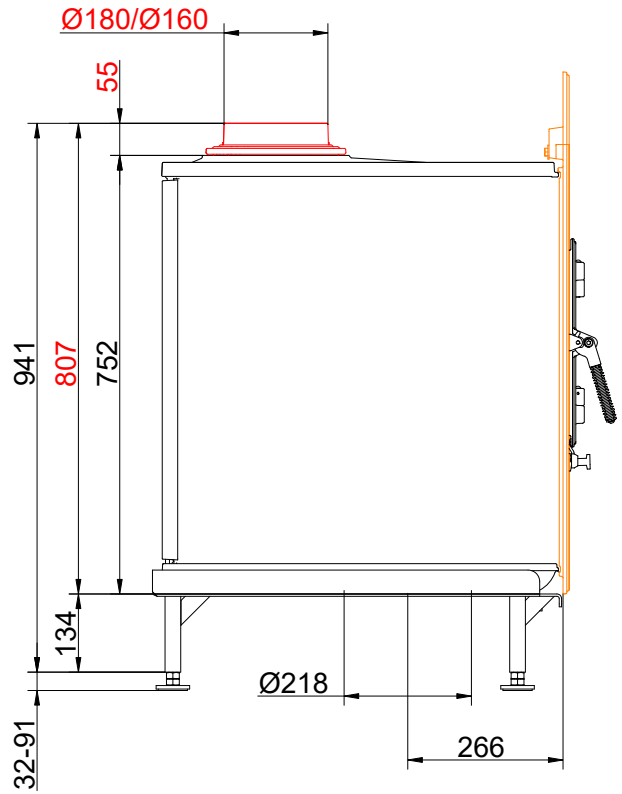
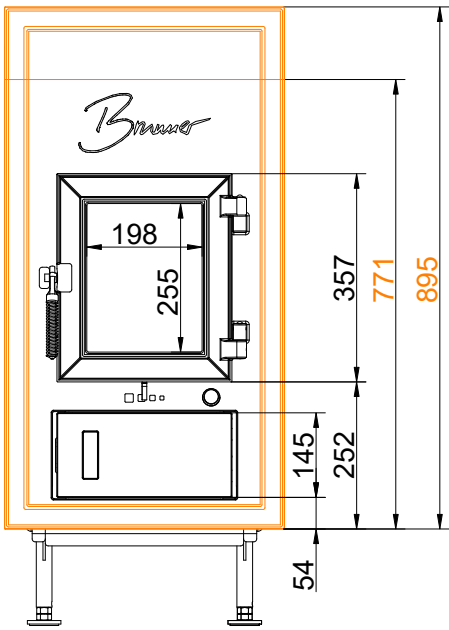

... cast iron front plate 895 x 480

Dimension sheets - WF_R 50

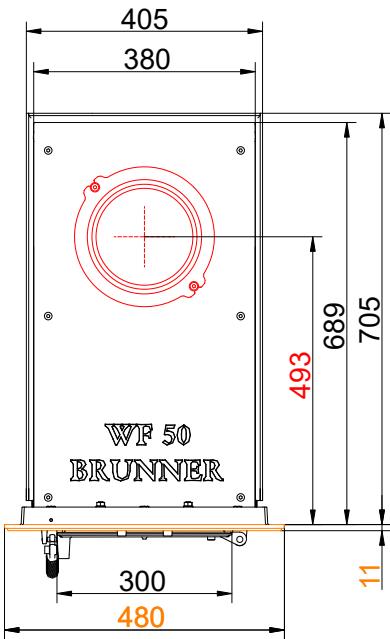
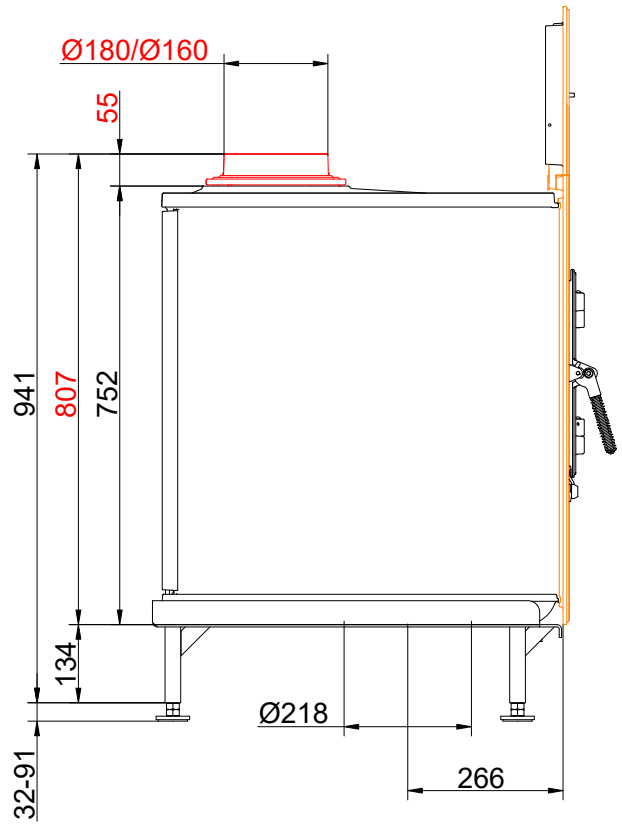
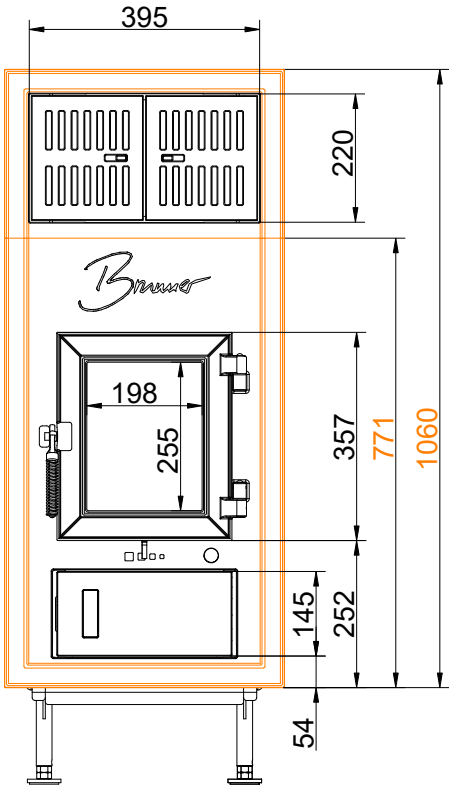

... cast iron front plate 1060 x 480

Dimension sheets - WF_R 50

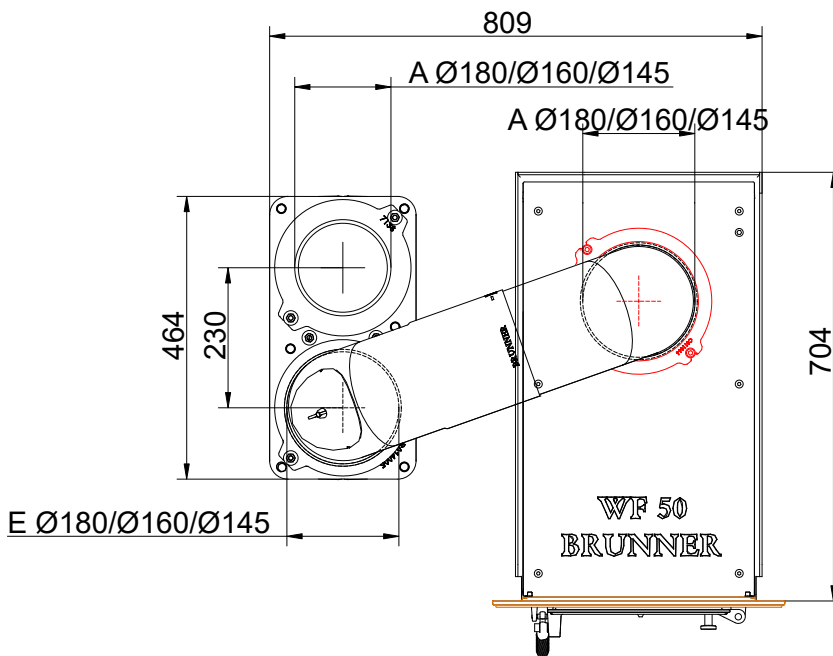
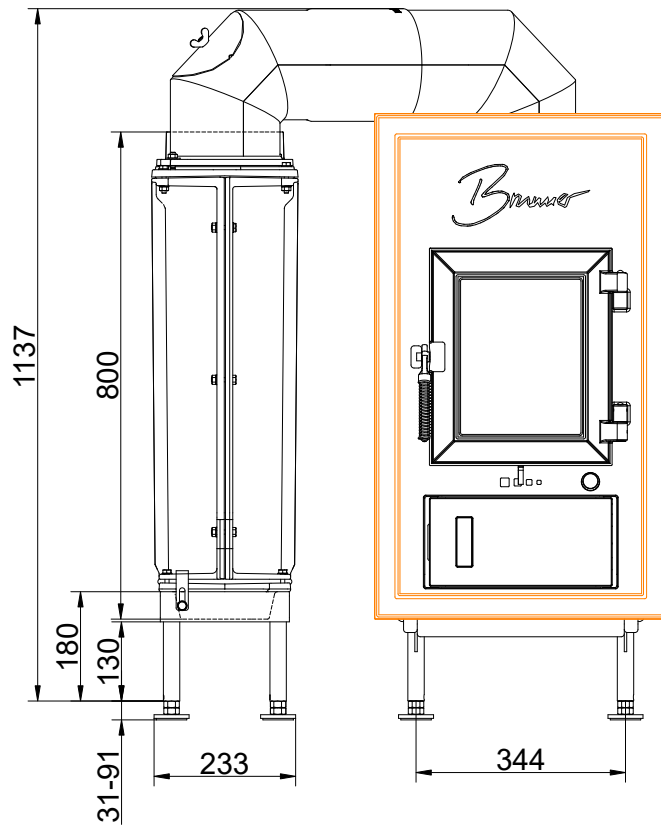

... with GNF 8 at the side

Dimension sheets - WF_R 50

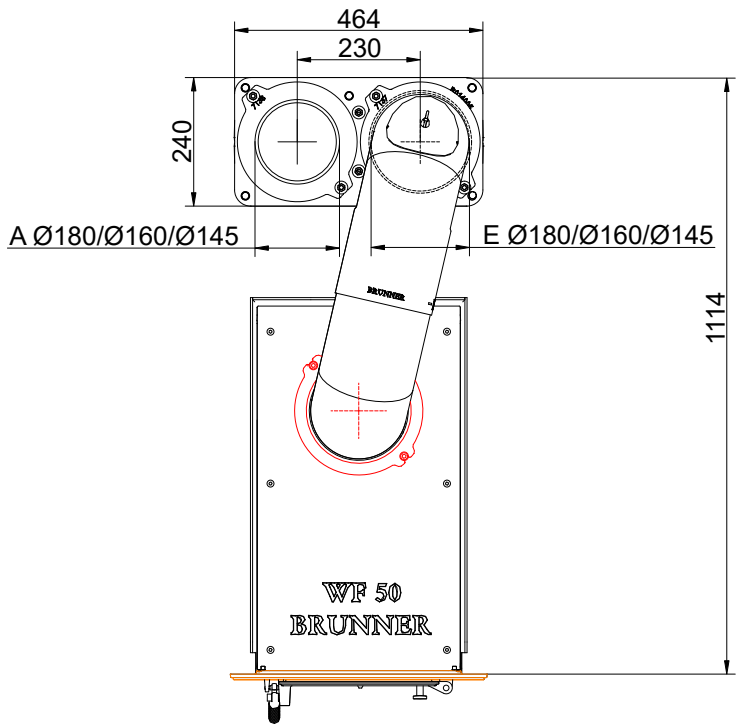
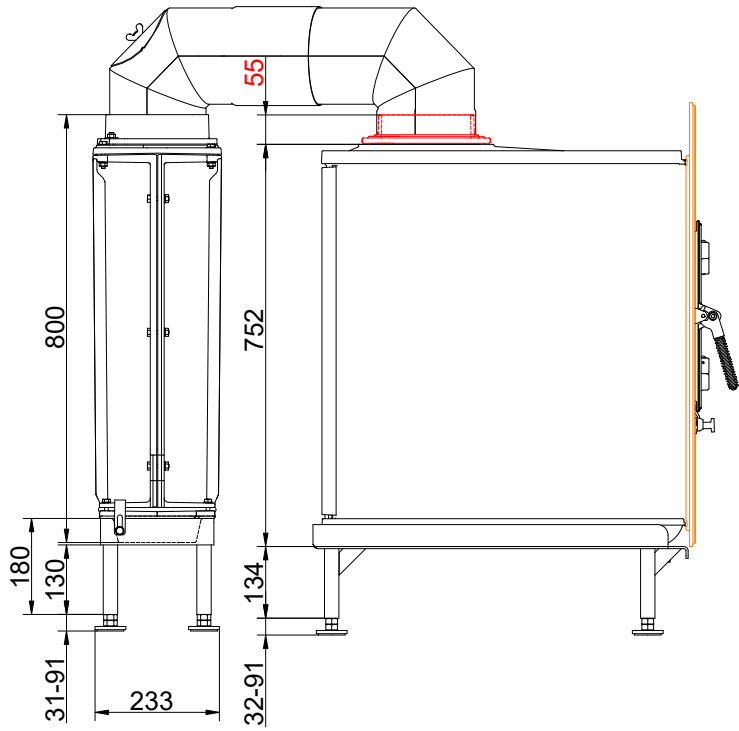
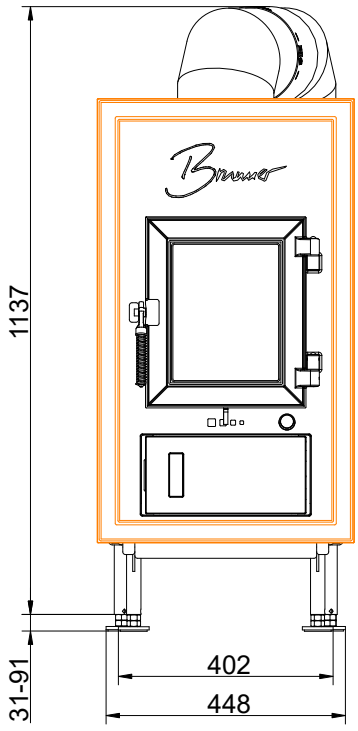

... with GNF 8 behind

Dimension sheets - WF_R 50

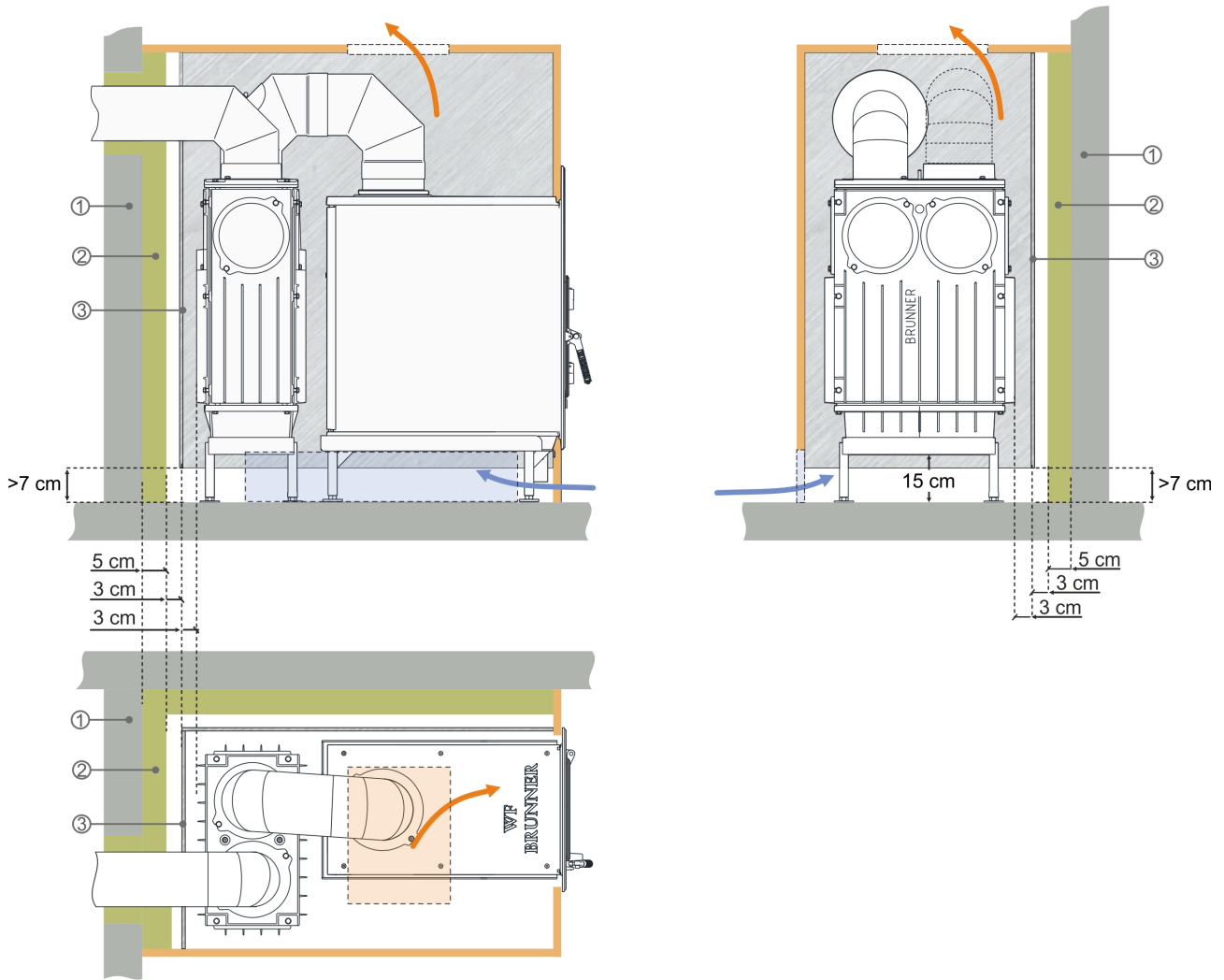

**Alternative thermal insulation with heat protection sheet^{x)} in front of insulation layer ^{xx)}.
 1 add-on wall (non-combustible), 2 Promasil 950KS, 3 hot-dip galvanized heat protection sheet (not black).**

^{x)} Heat protection sheet (no black sheet!) is attached to the insulation layer on site using spacers
^{xx)} Values determined with air cross-sections recorded by testing; stove envelope designed to dissipate heat

We suggest for CAD planning Palette CAD. Permanent updated drawings: www.brunner.de
 Frames/ flue gas outlet connection/ combustion air supply connection/ front variants/ support bearing are marked in color.

Planning and installation - WF_R 50

Tested according to		EN 13229 W	Lignite EN 13229
Values measured at		Rated power ¹⁾	Rated power ¹⁾
Suitable for all construction types according to rules		OK	OK
Data for functional demonstration			
Rated heat power	kW	9	9
Fire wood volume	kg/h	2.8	2.1
Combustion performance	kW	11	11
Flue gas mass flow	g/s	7.5	8.0
Outlet temperature (before reheating surface)	°C	500	455
Flue gas temperature after:			
1 x adjoining cast iron radiator (GNF 8)	°C	220	210
4,0 m ceramic accumulator ²⁾	°C	180	170
2,6 m accumulation stones (MSS) ²⁾	°C	180	170
Necessary supply pressure	Pa	12	12
Combustion air consumption	m ³ /h	23	18
Combustion air connection Ø	mm	125	125
Heating gas temperature (before the hood/dome variant)			
insert flue outlet nozzle	°C	430	520
Heat distribution			
Insert / reheating surface	%	50 / 40	50 / 40
Glass pane (single / double)	%	10 / -	10 / -
Cross-section of gratings ³⁾			
exhaust warm air	cm ²	500 / 200 / 500	500 / 200 / 500
Recirculation air	cm ²	500 / 200 / 500	500 / 200 / 500
Minimal distances of the fireplace			
to cladding, insulation layer	cm	8	8
to mounting floor	cm	15	15
Thermal insulation without / with air gratings ⁴⁾			
Mounting wall	cm	14 / 12	14 / 12
Floor	cm	0	0
Ceiling	cm	22 / 17	22 / 17
Brick lining for combustible wall	cm	10	10
Weight			
Fireplace / combustion chamber	kg	178 / 50 / 228	
Meets requirement/limit values for:			
Germany/ Austria / Switzerland / Norway		1.BImSchV (Stufe 2) / 15a BvG (2015) / LRV / -	

1) Indications to "Rated power" determined with metallic reheating surface and Double elbow

2) Approximate value

3) for fireplace inserts / flue gas pipe / metallic reheating surface

4) Values determined with air cross-sections evaluated by testing; stove cladding is heat emitting.

Product data sheet according to (EU) 2015/1186:

Supplier's name or trademark	Ulrich Brunner GmbH
Model identifier:	WFR 50
Energy efficiency class:	A+
Direct heat output:	9,0 kW
Indirect heat output:	N.A. kW
Energy efficiency index:	109
Fuel energy efficiency (at nominal heat output):	82,0 %
Fuel energy efficiency (at minimum load):	N.A. %
Special precautions: see supplied product documentation	

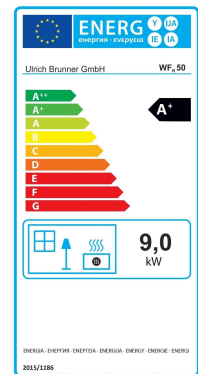

Ulrich Brunner GmbH
Zellhuber Ring 17-18
D-84307 Eggenfelden
Tel.: +49 (0) 8721/771-0 / Fax: +49 (0) 8721/771-100
Email: info@brunner.de

Technical and assortment changes as well as errors and misprints reserved.
Reprinting and reproduction, even in part, only with the express permission of the publisher.

Art.Nr.: 201611